

# Multi-stage centrifugal pump DPV

Technical specification booklet

series: DPV(C/S) 2 - 4 - 6 - 10 - 15 - 25 - 40 - 60 - 85 - 125

50Hz (DIN/IEC)

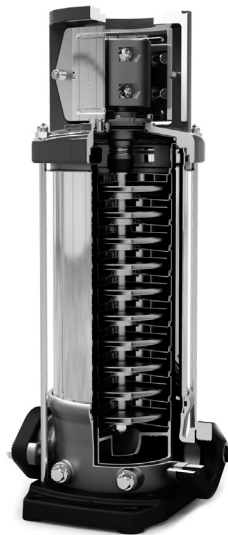

# 1 Pump introduction

1.1	General .....	4
1.2	Model key.....	4
1.3	Operation .....	5
1.4	Measuring, draining and venting.....	6
1.5	Working range.....	6
1.6	Basic material variants.....	7
1.7	Pump bearing.....	7
1.8	Modular selection.....	7
1.9	Approvals.....	8

# 2 Performance characteristics

2.1	Performance range .....	9
2.2	Performance curve details .....	9
2.3	Minimum efficiency index.....	10
2.4	Performance with variable frequency drive.....	10
2.5	How to read the values from the curves .....	11
2.6	Hydraulic performance curve DPV(C/S) 2 B - 50Hz -2 pole (2900 rpm).....	13
2.7	Hydraulic performance curve DPV(C/S) 4 B - 50Hz - 2 pole (2900 rpm).....	14
2.8	Hydraulic performance curve DPV(C/S) 6 B - 50Hz - 2 pole (2900 rpm).....	15
2.9	Hydraulic performance curve DPV(C/S) 10 B - 50Hz - 2 pole (2900 rpm).....	16
2.10	Hydraulic performance curve DPV(C/S) 10 B - 50Hz - 4 pole (1450 rpm).....	17
2.11	Hydraulic performance curve DPV(C/S) 15 C - 50Hz - 2 pole (2900 rpm) .....	18
2.12	Hydraulic performance curve DPV(C/S) 15 C - 50Hz - 4 pole (1450 rpm) .....	19
2.13	Hydraulic performance curve DPV(C/S) 25 B - 50Hz - 2 pole (2900 rpm).....	20
2.14	Hydraulic performance curve DPV(C/S) 25 B - 50Hz - 4 pole (1450 rpm).....	21
2.15	Hydraulic performance curve DPV(C/S) 40 B - 50Hz - 2 pole (2900 rpm).....	22
2.16	Hydraulic performance curve DPV(C/S) 40 B - 50Hz - 4 pole (1450 rpm).....	23
2.17	Hydraulic performance curve DPV(C/S) 60 B - 50Hz - 2 pole (2900 rpm).....	24
2.18	Hydraulic performance curve DPV(C/S) 60 B - 50Hz - 4 pole (1450 rpm).....	25
2.19	Hydraulic performance curve DPV(C/S) 85 B - 50Hz - 2 pole (2900 rpm).....	26
2.20	Hydraulic performance curve DPV(C/S) 85 B - 50Hz - 4 pole (1450 rpm).....	27
2.21	Hydraulic performance curve DPV(C/S) 125 B - 50Hz - 2 pole (2900 rpm).....	28

# 3 Low NPSH impeller

3.1	General .....	29
3.2	Risks of cavitation: .....	29
3.3	Benefits of using low NPSH impeller: .....	29
3.4	Consequences by using a low NPSH impeller:.....	29
3.5	Calculation of NPSHa .....	29
3.6	Low NPSH curve DPV(C/S) 2 B - 50Hz - (2900 rpm) .....	31
3.7	Low NPSH curve DPV(C/S) 4 B - 50Hz - (2900 rpm) .....	32
3.8	Low NPSH curve DPV(C/S) 6 B - 50Hz - (2900 rpm) .....	33
3.9	Low NPSH curve DPV(C/S) 10 B - 50Hz - (2900 rpm) .....	34
3.10	Low NPSH curve DPV(C/S) 10 B - 50Hz - (1450 rpm) .....	35
3.11	Low NPSH curve DPV(C/S) 15 C - 50Hz - (2900 rpm).....	36
3.12	Low NPSH curve DPV(C/S) 15 C - 50Hz - (1450 rpm).....	37

# 4 Dimensions

4.1	DPV(C/S) 2 B - 50Hz - 2 pole - DIN.....	38
4.2	DPV(C/S) 4 B - 50Hz - 2 pole - DIN.....	40
4.3	DPV(C/S) 6 B - 50Hz - 2 pole - DIN.....	42
4.4	DPV(C/S) 10 B - 50Hz - 2 pole - DIN.....	44

4.5	DPV(C/S) 10 B - 50Hz - 4 pole - DIN .....	46
4.6	DPV(C/S) 15 C - 50Hz - 2 pole - DIN .....	48
4.8	DPV(C/S) 15 C - 50Hz - 4 pole - DIN .....	50
4.9	DPV(C/S) 25 B - 50Hz - 2 pole - DIN .....	52
4.10	DPV(C/S) 25 B - 50Hz - 4 pole - DIN .....	54
4.11	DPV(C/S) 40 B - 50Hz - 2 pole - DIN .....	56
4.12	DPV(C/S) 40 B - 50Hz - 4 pole - DIN .....	58
4.13	DPV(C/S) 60 B - 50Hz - 2 pole - DIN .....	60
4.14	DPV(C/S) 60 B - 50Hz - 4 pole - DIN .....	62
4.15	DPV(C/S) 85 B - 50Hz - 2 and 4 pole - DIN .....	64
4.16	DPV(C/S) 125 B - 50Hz - 2 pole - DIN .....	66
<b>5</b>	<b>Seals</b>	
5.1	Mechanical seal option specifications .....	68
<b>6</b>	<b>Motors and motor options</b>	
6.1	General .....	69
6.2	Options .....	69
6.3	Standard motor data .....	70
<b>7</b>	<b>Accessories</b>	
7.1	Thrust bearing housing (optional) .....	72
<b>8</b>	<b>Materials</b>	
8.1	Parts overview .....	73
<b>9</b>	<b>Medium handled</b>	
9.1	Medium handled .....	86



# 1 Pump introduction

## 1.1 General

The vertical, single or multi-stage centrifugal pump series are designed for pumping clean, or lightly aggressive, watery mediums.

Suction and discharge of the pump are in-line, making the pump easy to install.

The hydraulic assembly is driven by an electric motor. All hydraulic parts of the pump are made of stainless steel.

The vertical, multi-stage centrifugal DPV pumps are produced by DP Pumps.

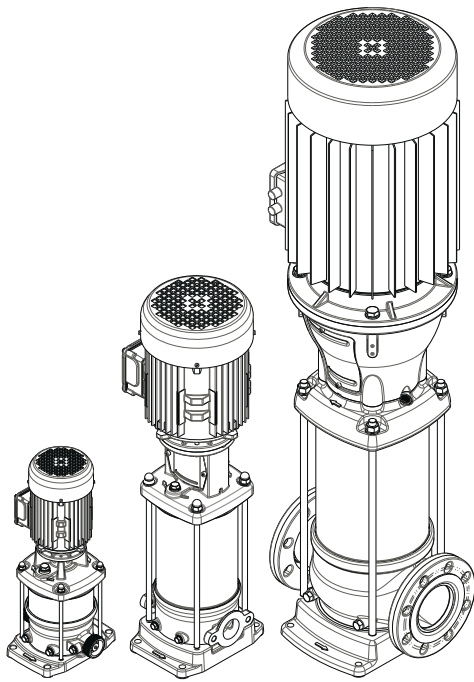

20090719

DPV  
2,4,6 B

DPV  
10 B,15 C

DPV  
25,40,60,85,125 B

## 1.2 Model key

Model key Example DPVSF 85/3-1 B

	DP	VS	F	85	/3	-1	B	
Label	DP							Product Label
Material/Construction		VC						Cast Iron pump foot and top bracket hydr. 1.4301 / AISI 304
		V						All wetted parts Stainless Steel 1.4301 / AISI 304
		VM						All wetted parts Stainless Steel 1.4301 / AISI 304 with closed coupled motor
		VS						All wetted parts Stainless Steel 1.4401 / AISI 316
Connections			E					Male thread (with non-return valve insert)
								Oval flange with female thread
			F					Round flange
			V					Victaulic connections
			T					Tri-clamp connections

	DP	VS	F	85	/3	-1	B	
				85				Capacity in m <sup>3</sup> /h at Q <sub>opt</sub>
					/3			Number of stages
					/3	-1		Number of stages of which one stage with reduced head
						L		Low NPSH impeller (model 2,4,6,10 en 15)
							B/C	Design version

### 1.3 Operation

Every stage (B) consists of an impeller and diffuser. The passage of this stage determines the capacity of the pump. The diameter of the stages is related to the centrifugal forces and its "stage pressure": the more stages, the more pressure.

This total capacity and raised pressure will be guided to the outside of the pump, between the pump stages and the outer sleeve (C) and the medium will leave the pump at the discharge connection (D).

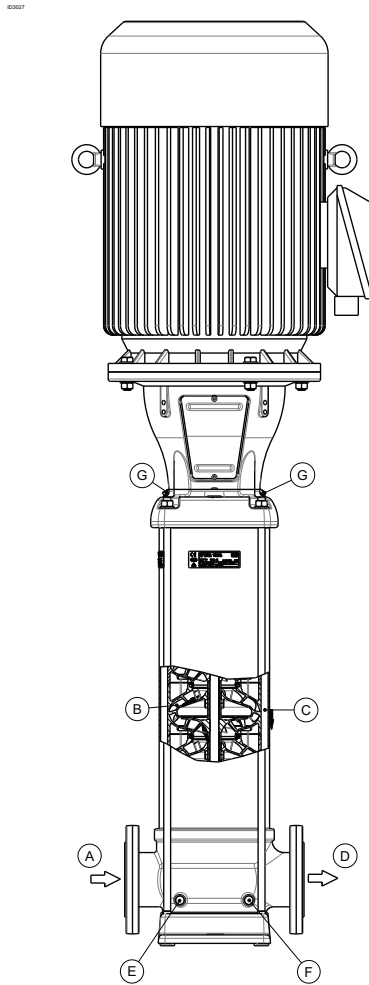

DPVF 85

20080190 A

During centrifugal operation of the pump a negative pressure is created at the inlet of the impeller. This negative pressure enables the medium to enter the pump at the suction connection (A).

## 1.4 Measuring, draining and venting

The pump is provided with plugs for measuring, draining and venting.

Connection (E) is meant to drain the inlet part of the pump. Or to measure the inlet / suction pressure using a G ¼ connection.

Connection (F) is meant to drain the outlet part of the pump. Or to measure the discharge pressure using a G ¼ connection.

Connections (G) are meant to vent the pump system when the pump is not in operation. Or to measure the discharge pressure of the pump using a G 3/8 connection.

## 1.5 Working range

The working range is depending on the application and a combination of pressure and temperature. For specific and detailed limits please consult the working ranges as described in the chapter 1.8 Modular selection. The overall working range of the pumps can be summarised as follows:

Specification of the working range

Pump type	DPV	note
Ambient temperature [°C]	-20 up to 40/50	1
Minimum inlet pressure	NPSH <sub>req.</sub> + 1m	
Viscosity [cSt]	1-100	2
Density [kg/m <sup>3</sup> ]	1000-2500	2
Cooling	forced motor cooling	3
Minimum frequency [Hz]	30	
Maximum frequency [Hz]	60	4
Allowable size of solids pumped	5µm to 1mm	

1. If the ambient temperature exceeds the above value or the motor is located more than 1000 m above sea level, the motor cooling is less effective and could require an adapted motor power. See table 5: Motor load dep. sea level or amb. temp or please contact your supplier for more detailed advice.
2. Deviation in viscosity and/or density could require an adapted motor power. Please contact your supplier for more detailed advice.
3. The free space above the motor cooling fan must be at least 1/4 of the diameter of the inlet of the cooling fan in order to have a sufficient flow of (cooling) air.
4. Pumps that are intended for 50 Hz operation, may not be connected to 60Hz power supply.

### 1.5.1 Minimum capacity

For minimum capacity at medium temperature of 20 °C, see table: Minimum capacity (Q<sub>min</sub>); for higher temperatures, see table: Minimum capacity vs. temperature (in % of Q optimum).

To prevent the pump from overheating, gathering gas, cavitation etc. a minimum capacity has to be secured. The minimum capacity corresponds to all percentage of the optimum flow Q<sub>opt</sub> in relation to the temperature of the liquid pumped.

Minimum capacity (Q<sub>min</sub>)

size	Q <sub>min</sub> [m <sup>3</sup> /h]			
	50 Hz		60 Hz	
	2 pole	4 pole	2 pole	4 pole
2	0,2		0,2	
4	0,4		0,5	
6	0,6		0,8	
10	1,1	0,5	1,3	0,6
15	1,9	0,9	2,3	1,1
25	2,8	1,4	3,1	1,6
40	4	1,9	4,9	2,3
60	5,3	2,6	6,5	3,2
85	8,5	4,3	10,2	5,1
125	13,1		15,8	

Minimum capacity vs. temperature (in % of Q optimum)

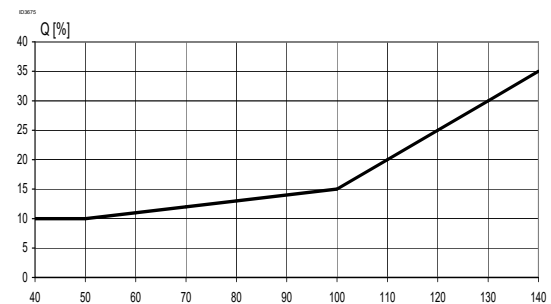

3675

### 1.5.2 Ambient temperature and higher altitude

If the ambient temperature exceeds the above value, or if the motor is located more than 1000 m above sea level, the motor cooling is less effective and could require an adapted motor power. See below table for the increased percentage of the motor power or contact your supplier for more detailed advice. Increase of required motor power

Ambient temperature [°C]	Above sea level [m]	Increase of required power
40	1000	0%
45	1625	2%
50	2250	5%
55	2875	11%
60	3500	18%
65	4125	25%
70	4750	33%

### 1.6 Basic material variants

Basic material variants

Model	Hydraulic	Casing	Sealing
V	1.4301	1.4308	EPDM
VS	1.4404	1.4408	FPM
VC 2-60 & 125	1.4301	JS1030	EPDM
VC 85	1.4301	JL1040	EPDM

### 1.7 Pump bearing

Medium lubricated stage bearing  
Tungsten Carbide against Ceramic

Optional pump bearing TuC/TuC

In case of severe applications or using conditions, such as hot water, boiler feed (max 140 °C or when the pump experiences an avoidable dry running for a short time. The standard ceramic bearing material can be replaced / exchanged by a more resistant TuC/TuC bearing material.

Due to the specific material characteristics of Tungsten Carbide, the TuC/TuC material is even more resistant for the above mentioned severe conditions and will enhance the durability and lifecycle of the pump.

When combining the use of the optional TuC/TuC bearing material and the optional low NPSH kit, the pump can be made even more suitable for the above mentioned severe applications or using conditions.

The optional combinations TuC/TuC bearing material and low NPSH kit are available for the vertical pump models DPVCF 2, 4, 6, 10 and 15.

Up to now only the optional TuC/TuC bearing material is available for pump models DPVCF 2 up to and including 125.

For other possible pump options or features, please contact our sales department.

### 1.8 Modular selection

To suit almost every application the pump is assembled out of modules which can be selected depending on the required working range. Basic modules are:

- **Basic pump model**, which defines the capacity, pressure and basic material.  
Temperature range -20 up to 140 °C, with the exception of the DPV 125 this pump can be used upto 120 °C.
- **Connections**, which define the suction and discharge connection as well as the base plate.  
VE casing (with non return valve) max. temperature 90 °C. Other connections have same temperature range as basic pump model.
- **Sealings**, which define the elastomers, the mechanical seal and the shaft seal type.  
Temperature range, see chapter 5.1
- **Electric motor**, which defines all requirements of the motor such as motor size, power, voltage, frequency and all possible motor accessories.  
Due to mono-block motor version VM, max. fluid temperature is 60 °C

## 1.9 Approvals

CE Conformity with European Safety Directive  
ACS Drinking Water Approval (F)  
WRAS Drinking Water Approval (GB)  
ATEX Conformity with "ATmosphères EXplosibles"  
Directive



## 2 Performance characteristics

### 2.1 Performance range

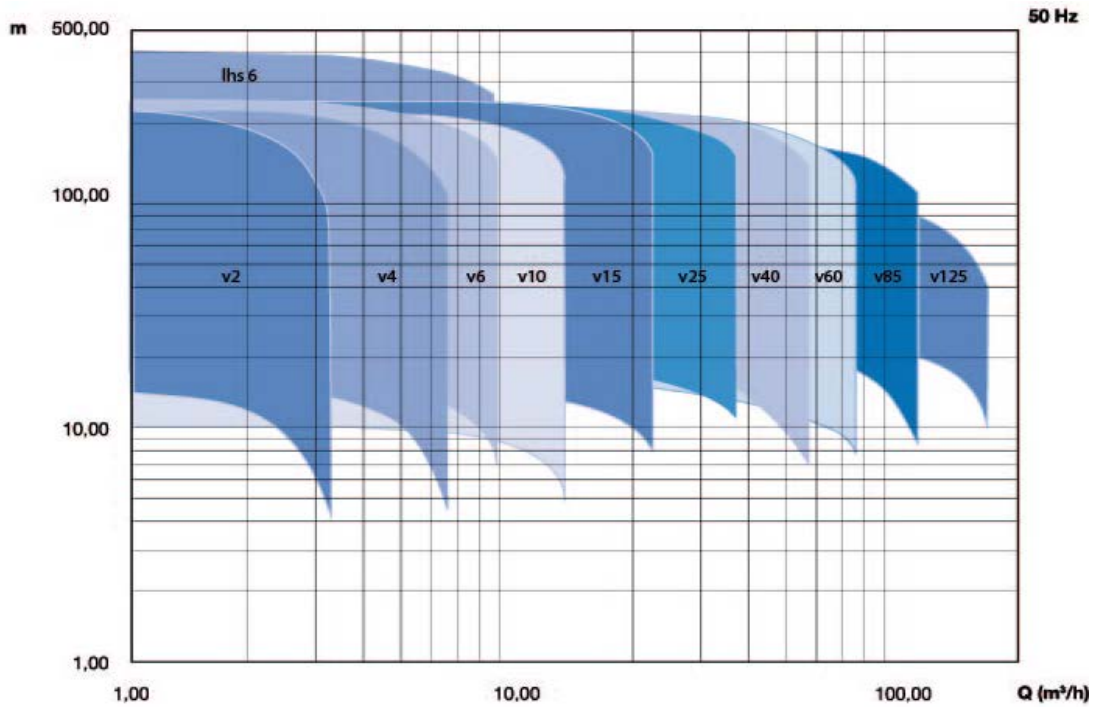

Performance range DPV (C/S) B/C 50Hz

### 2.2 Performance curve details

The performance diagrams give a global overview of all the pump models the shaded models are mentioned in this documentation. Detailed characteristics are given for each model showing the hydraulic efficiency,  $NPSH_{req}$ , and shaft power as well.

The performance of the pump depends on the number of stages. As per example:

DPV 4/2 B:	model DPV 4 B	2 stages with 2 full head impellers
DPV 85/4-1 B	model DPV 85 B	4 stages with 3 full head impellers and 1 reduced impeller

The detailed performance curves are in accordance with ISO 9906:2012 (Grade 3B).

The pumps can be configured with multiple types of motors. For the published hydraulic curves, such as Q/H, efficiency and power, we have assumed a fixed nominal speed of 2900 rpm. for the 2 pole motors and 1450 rpm for the 4 pole motors.

The characteristics given are based on:

- De-aerated water at a temperature of 20 °C
- Density of 1,0 kg/dm<sup>3</sup>
- Kinematical viscosity of 1 mm<sup>2</sup>/s (1 cst)

## 2.3 Minimum efficiency index

The minimum energy-efficiency level according to the ErP regulations for water pumps is specified by the minimum efficiency index MEI. A high MEI value indicates a high efficiency of the determined pump. From 1 January 2015 on the minimum efficiency index (MEI) for standardised water pumps is  $\geq 0.4$ .

The following MEI values apply for the pump range design version B/C:

Minimum efficiency index

Pump range	Minimum Efficiency index
DPV 2B	MEI $\geq 0.70$
DPV 4B	MEI $\geq 0.70$
DPV 6B	MEI $\geq 0.70$
DPV 10B	MEI $\geq 0.70$
DPV 15C	MEI $\geq 0.70$
DPV 25B	MEI $\geq 0.70$
DPV 40B	MEI $\geq 0.70$
DPV 60B	MEI $\geq 0.70$
DPV 85B	MEI $\geq 0.60$
DPV 125B	MEI $\geq 0.70$

## 2.4 Performance with variable frequency drive

The minimum frequency of the DP motor should be limited to 30 Hz. When the rotational speed exceeds the nominal speed of the motor, make sure that the power output of the motor is suitable to drive the corresponding pump model.

The performance of the pump differs from the fixed speed performance according to the recalculation scheme.

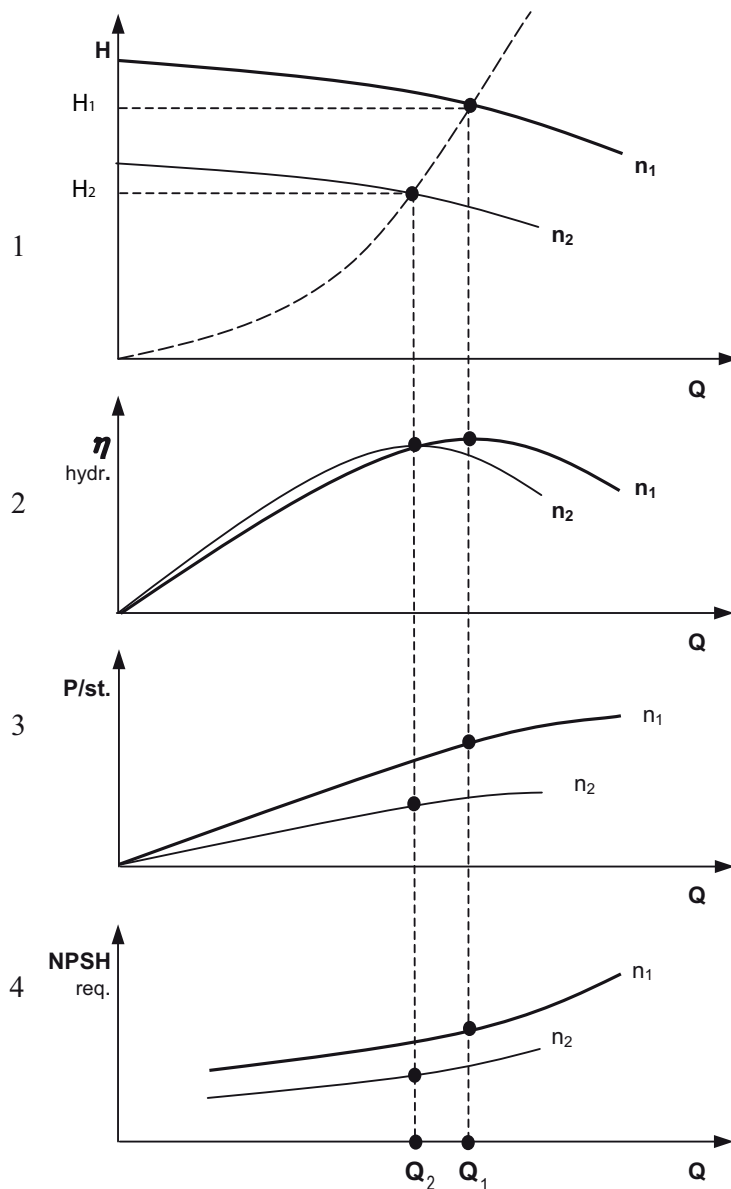

$$Q_2 = \frac{n_2}{n_1} \cdot Q_1$$

$$H_2 = \left(\frac{n_2}{n_1}\right)^2 \cdot H_1$$

$$\eta_2 = 1 - \left( (1 - \eta_1) \cdot \left(\frac{n_1}{n_2}\right)^{0.1} \right)$$

$$P_2 = \left(\frac{n_2}{n_1}\right)^3 \cdot P_1$$

$$NPSH_2 = \left(\frac{n_2}{n_1}\right)^2 \cdot NPSH_1$$

### Performance characteristics

## 2.5 How to read the values from the curves

To find the required hydraulic information from the published curves, it is important to know the application in which the pump has to be installed.

There are two main distinction to be made:

- A Flow determined (like booster sets and cleaning) → Opening taps
- B Pressure determined (like boiler feed and reverse osmosis systems) → Facing counter pressure.

How to read the motor power.

The required motor power can be read in the curve 'Power input'.

Attention: the power value as mentioned in this curve is the required power per stage. For some pump types there are two lines in the curve this is related to the full impeller or reduced impeller [-1].



3227

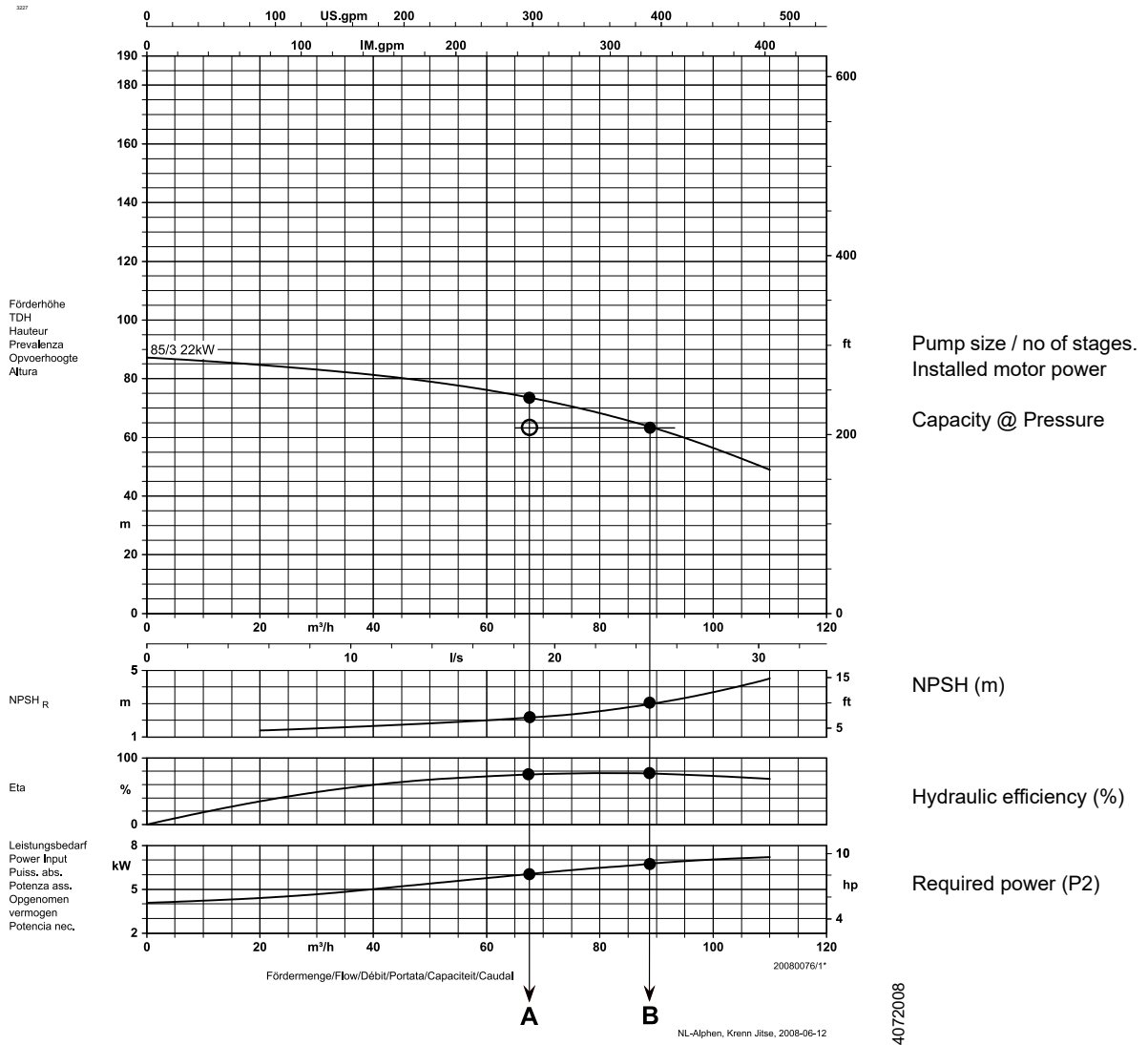

3227/04072008

*How to read the values from the curves*

- Calculated duty point
- Actual hydraulic performance
- A Flow determined
- B Pressure determined

## 2.6 Hydraulic performance curve DPV(C/S) 2 B - 50Hz -2 pole (2900 rpm)

02004

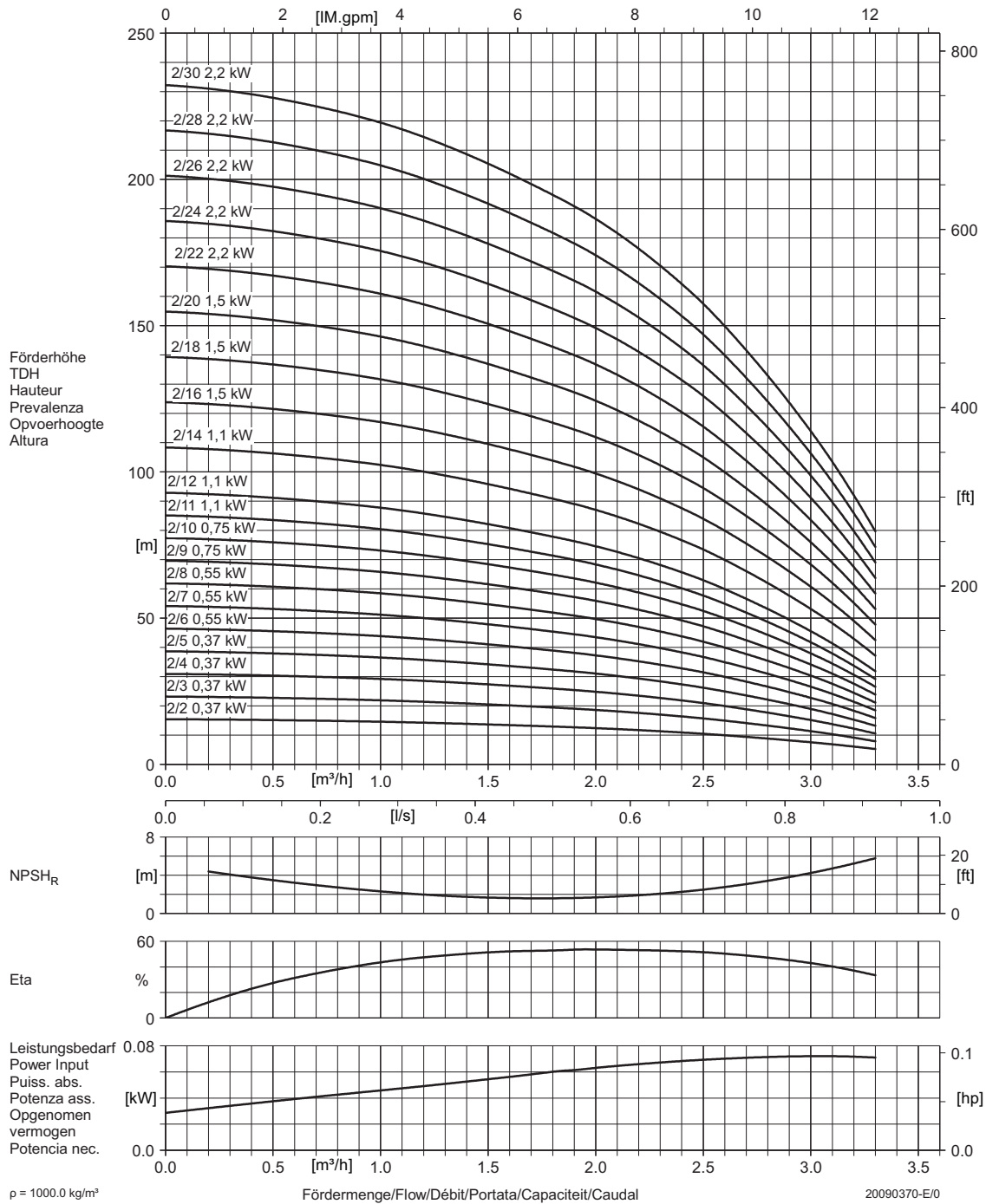

Performance curve DPV(C/S) 2 B - 50Hz - 2 pole



## 2.7 Hydraulic performance curve DPV(C/S) 4 B - 50Hz - 2 pole (2900 rpm)

0244

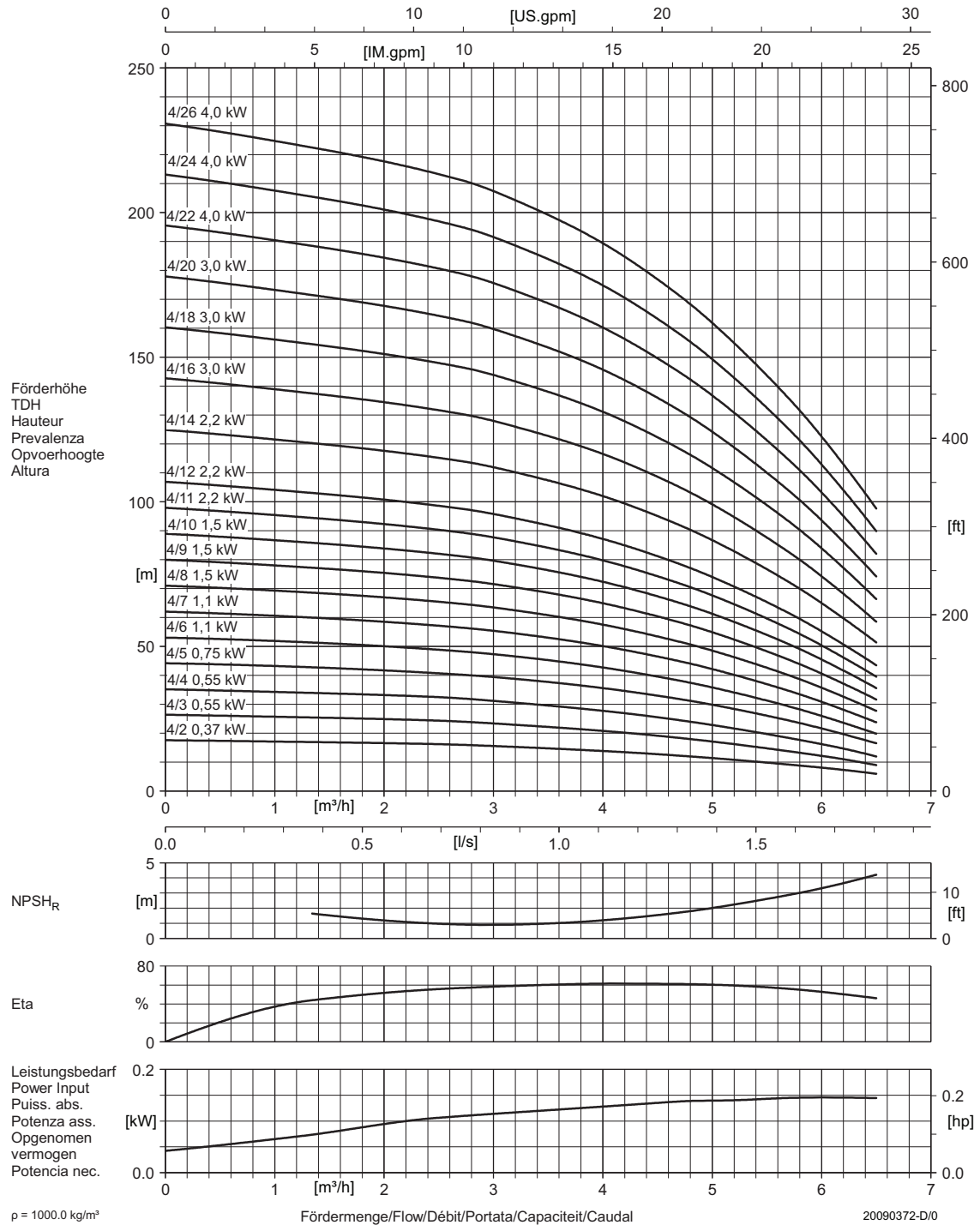

## 2.8 Hydraulic performance curve DPV(C/S) 6 B - 50Hz - 2 pole (2900 rpm)

02020

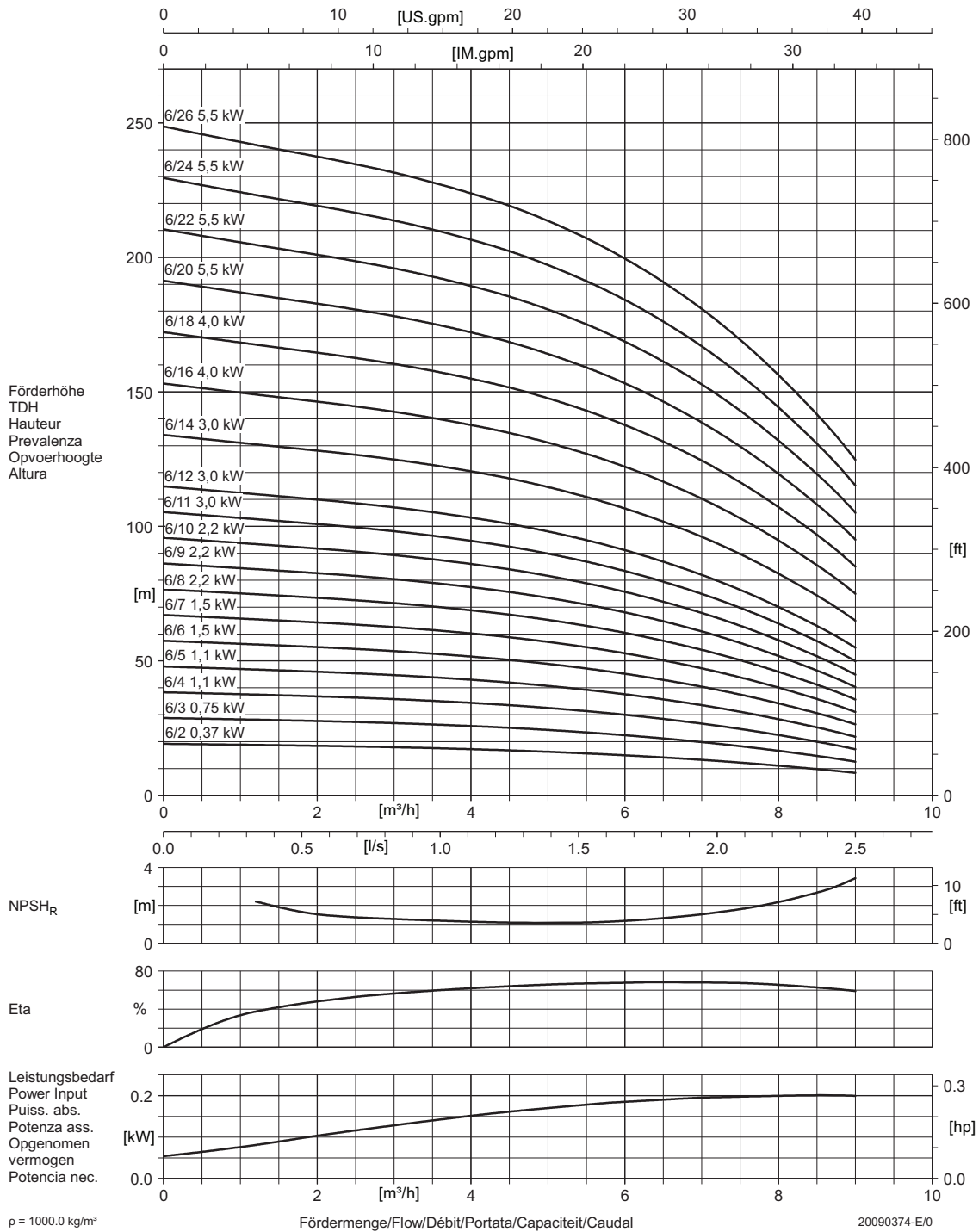

## 2.9 Hydraulic performance curve DPV(C/S) 10 B - 50Hz - 2 pole (2900 rpm)

0202

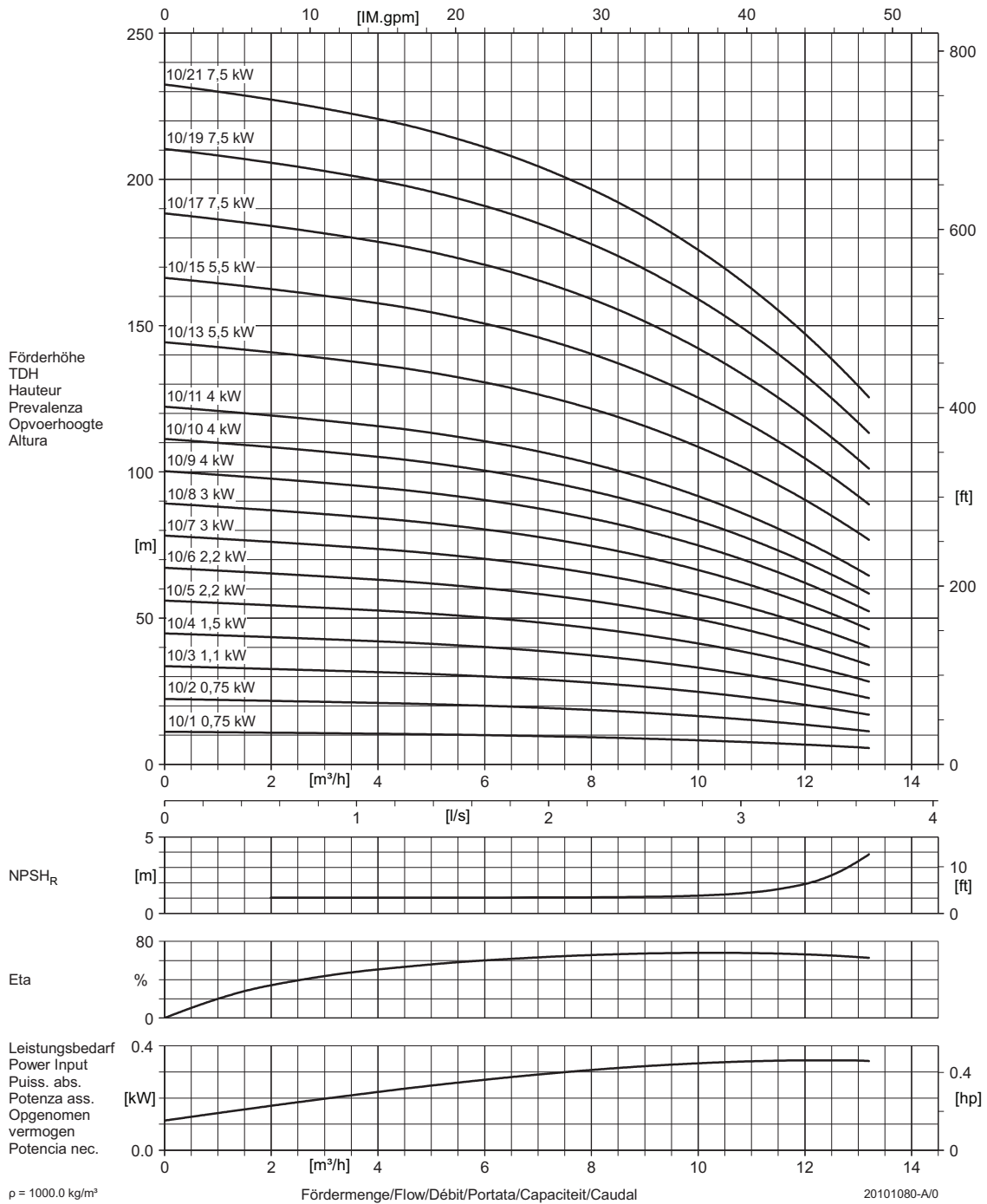



## 2.10 Hydraulic performance curve DPV(C/S) 10 B - 50Hz - 4 pole (1450 rpm)

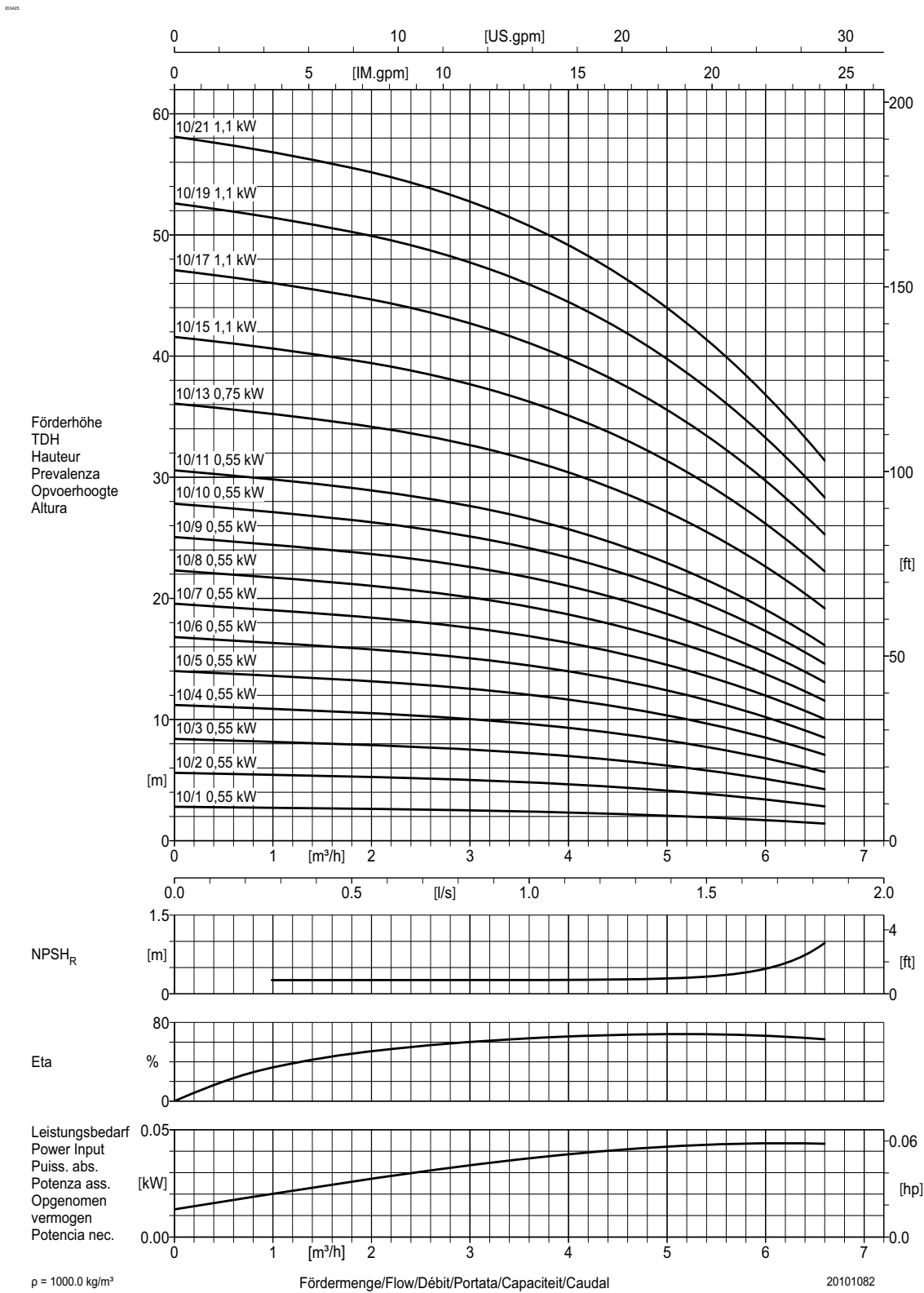

Performance curve DPV(C/S) 10 B - 50Hz - 4 pole

20101082



## 2.11 Hydraulic performance curve DPV(C/S) 15 C - 50Hz - 2 pole (2900 rpm)

0202

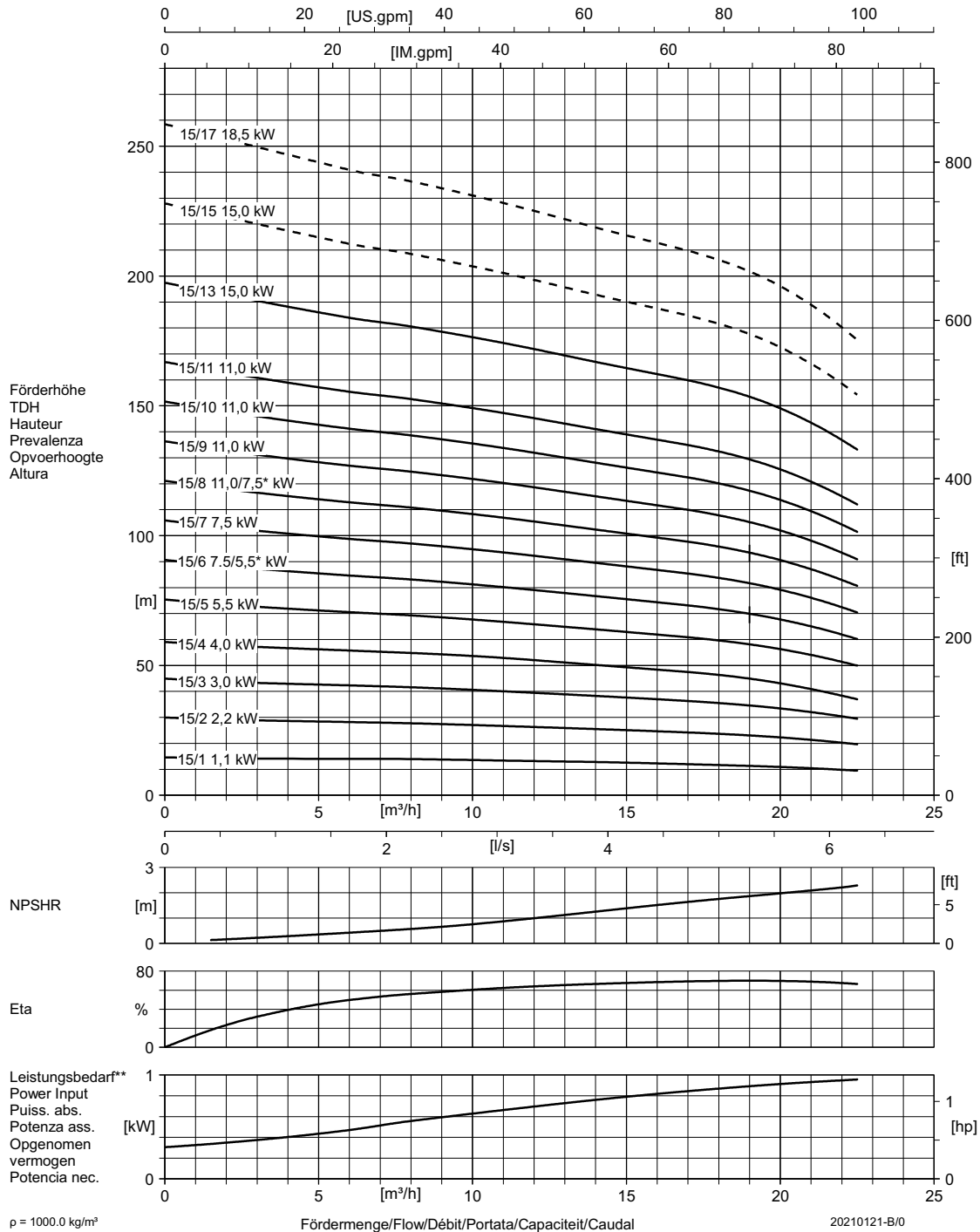

\*Decreased motor power:  $Q_{max} = 19 \text{ m}^3/\text{h}$

\*\*Power input based on a V 15/3 C of this hydraulic speed design

Performance curve DPV(C/S) 15 C - 50Hz - 2 pole

## 2.12 Hydraulic performance curve DPV(C/S) 15 C - 50Hz - 4 pole (1450 rpm)

0202

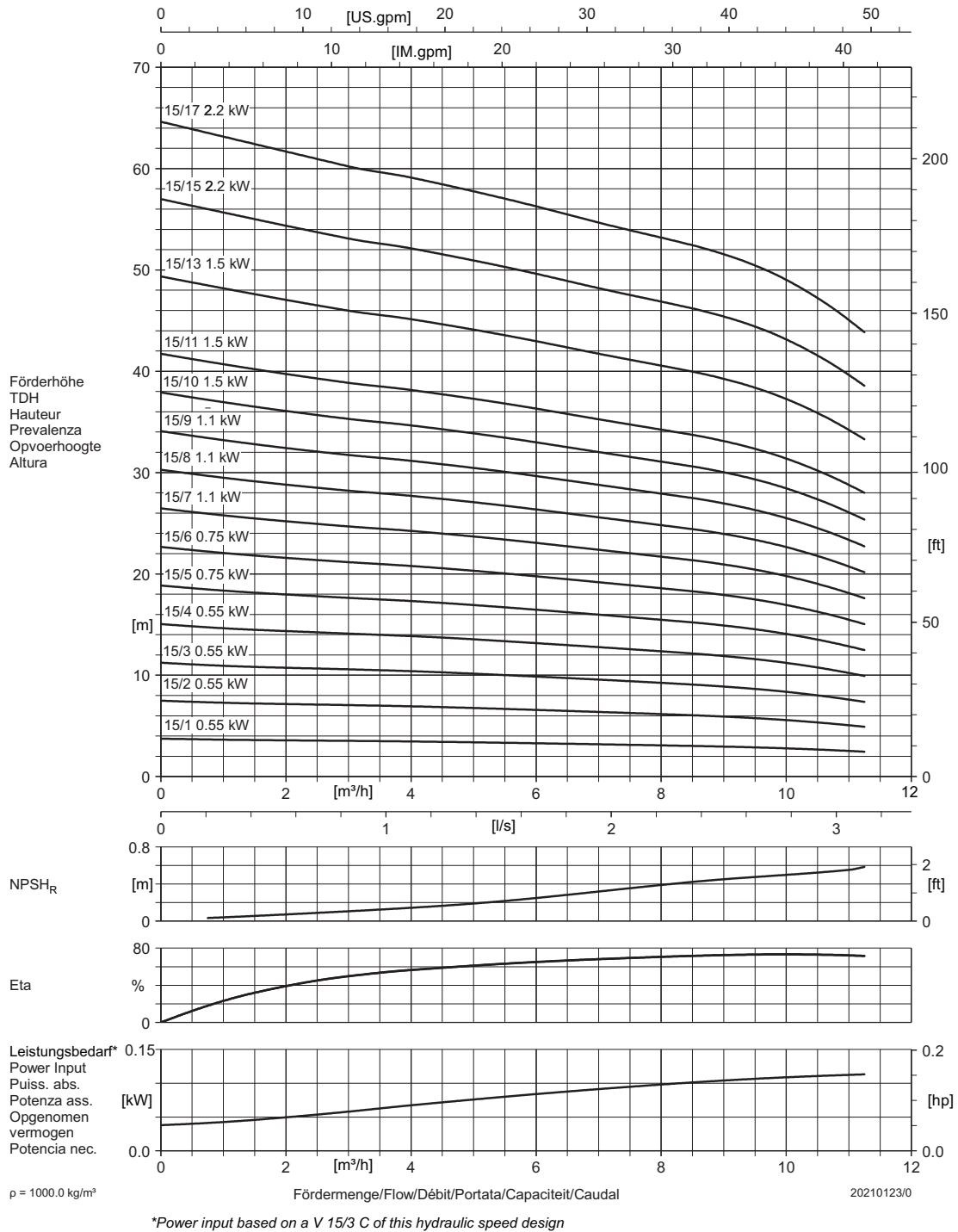

## 2.13 Hydraulic performance curve DPV(C/S) 25 B - 50Hz - 2 pole (2900 rpm)

02229

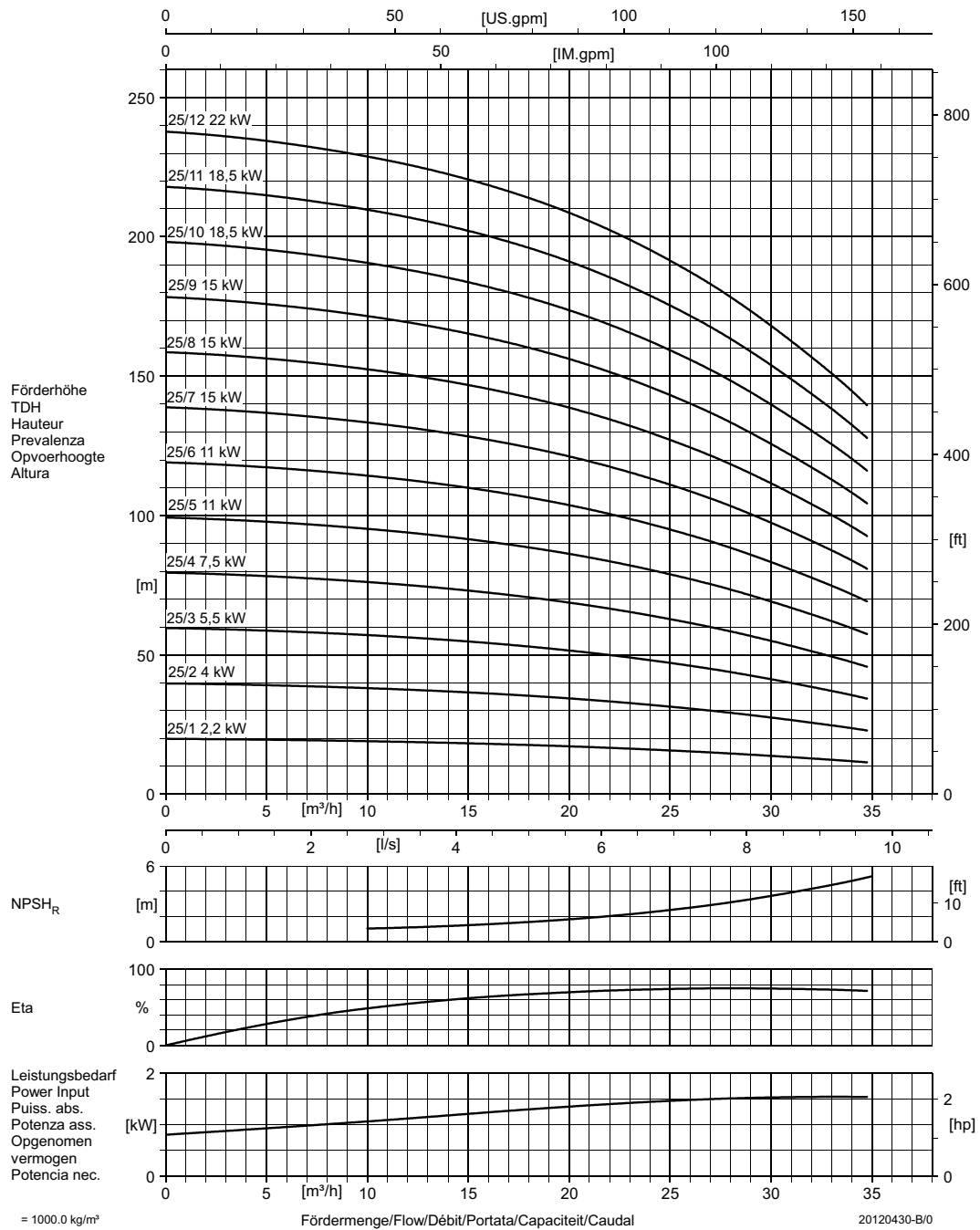

## 2.14 Hydraulic performance curve DPV(C/S) 25 B - 50Hz - 4 pole (1450 rpm)

0222

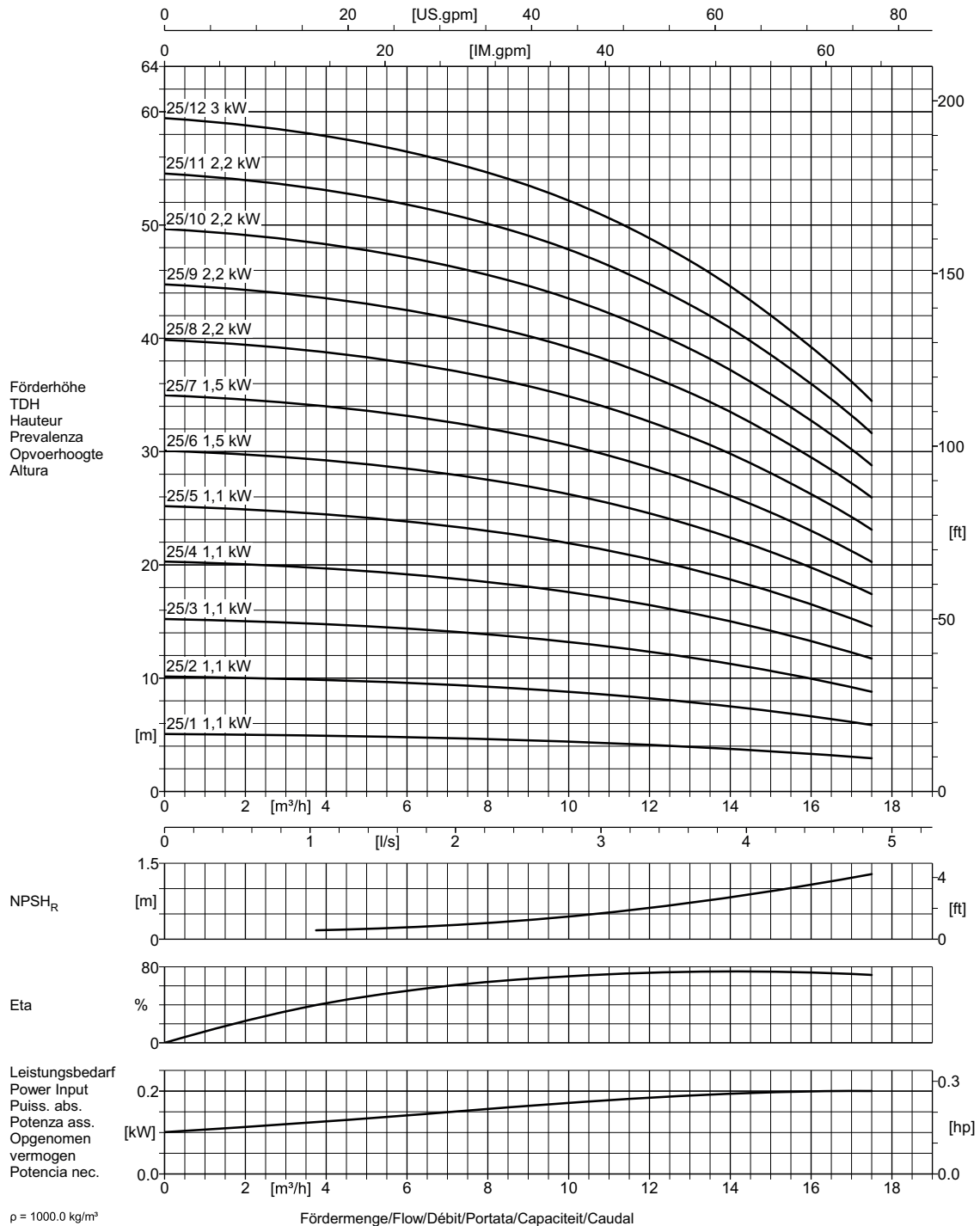

## 2.15 Hydraulic performance curve DPV(C/S) 40 B - 50Hz - 2 pole (2900 rpm)

0229

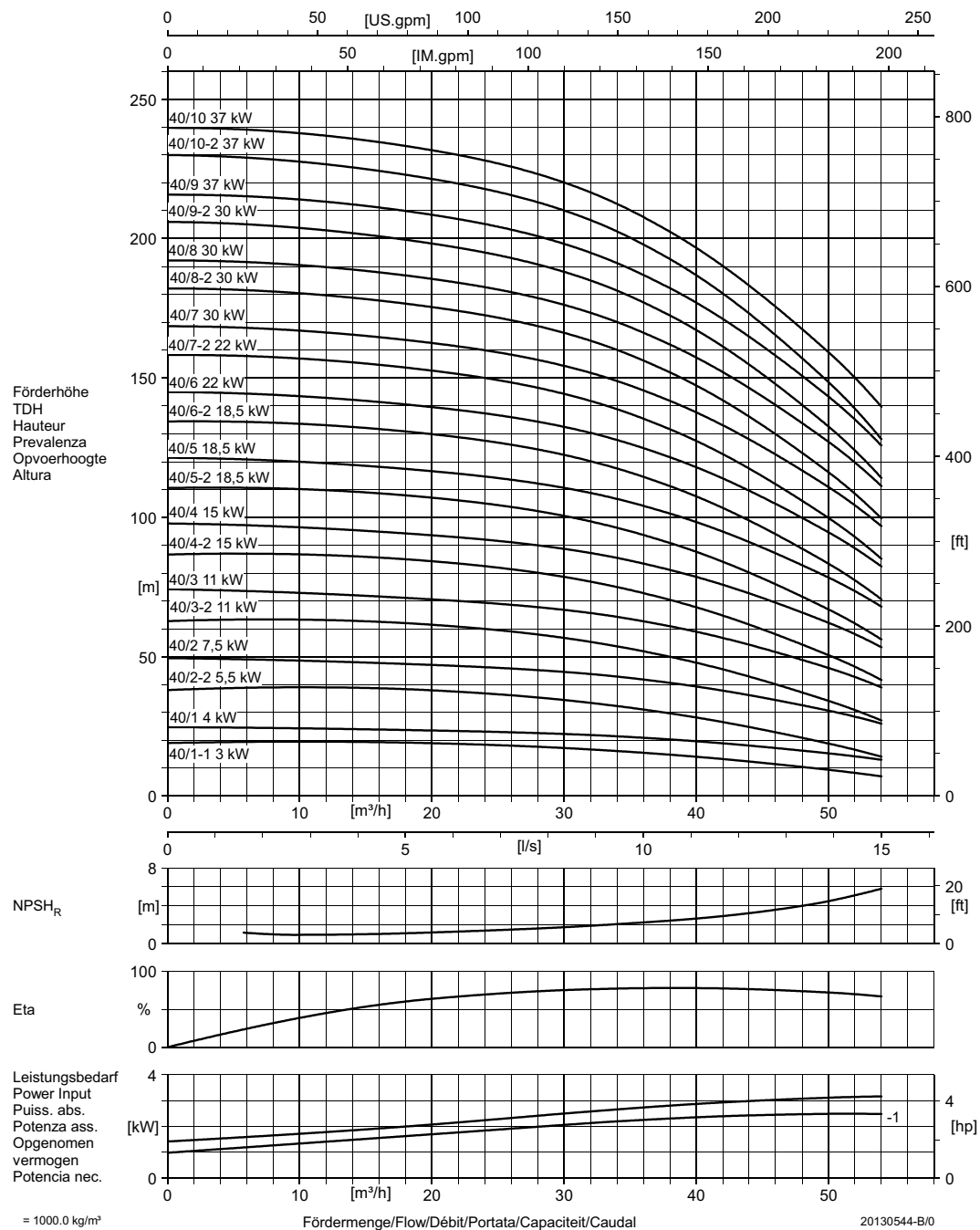

## 2.16 Hydraulic performance curve DPV(C/S) 40 B - 50Hz - 4 pole (1450 rpm)

0222

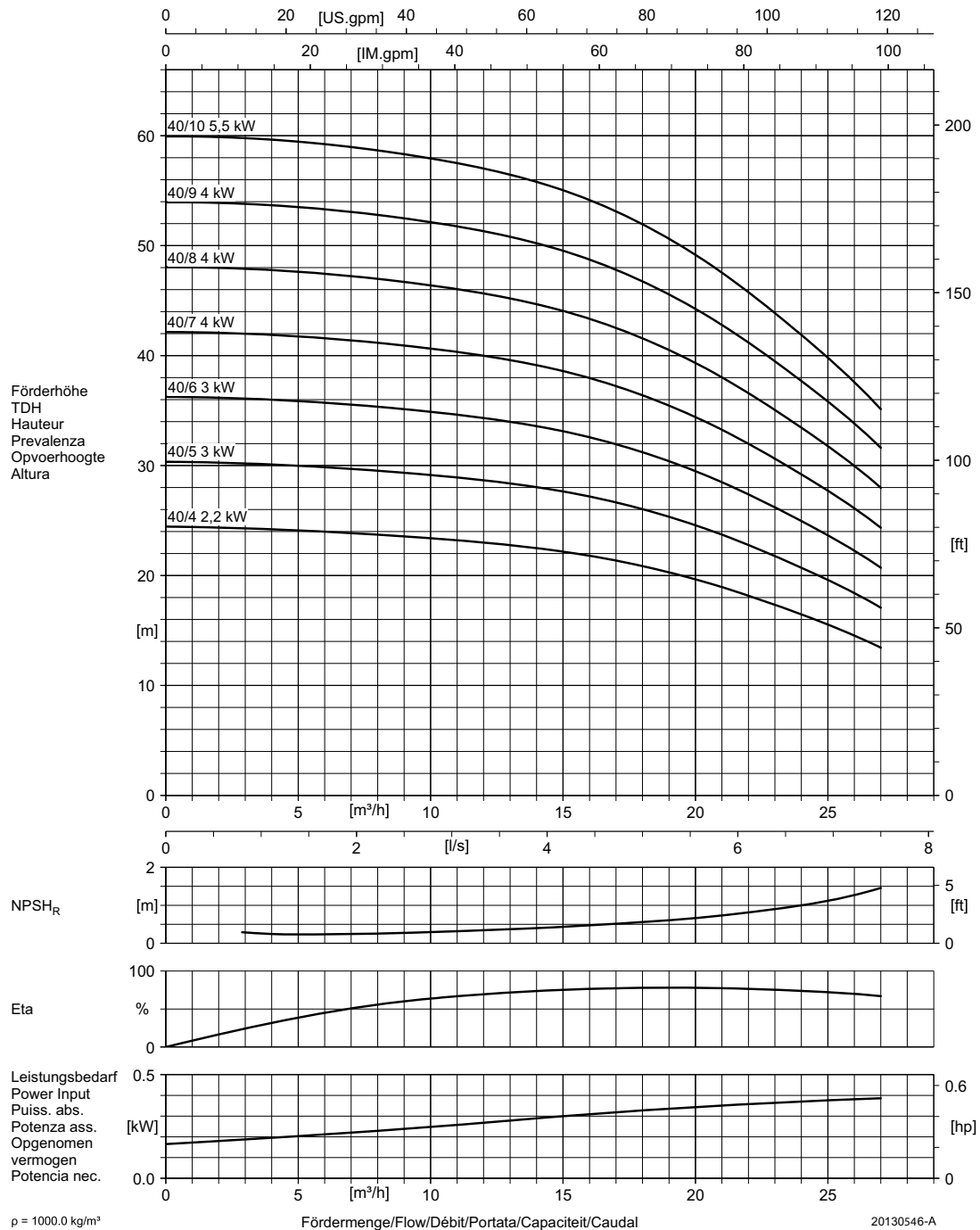

## 2.17 Hydraulic performance curve DPV(C/S) 60 B - 50Hz - 2 pole (2900 rpm)

0222

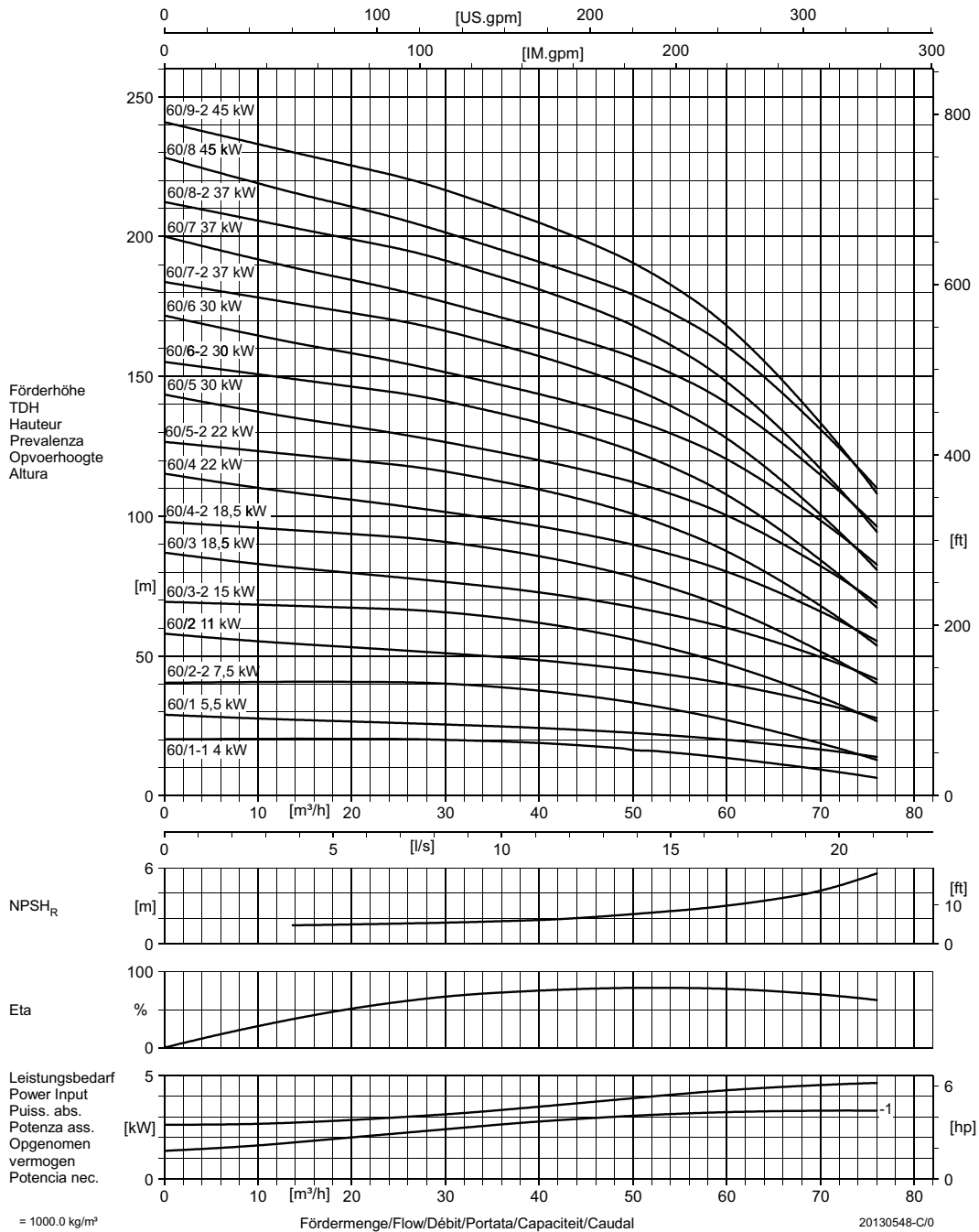



## 2.18 Hydraulic performance curve DPV(C/S) 60 B - 50Hz - 4 pole (1450 rpm)

0222

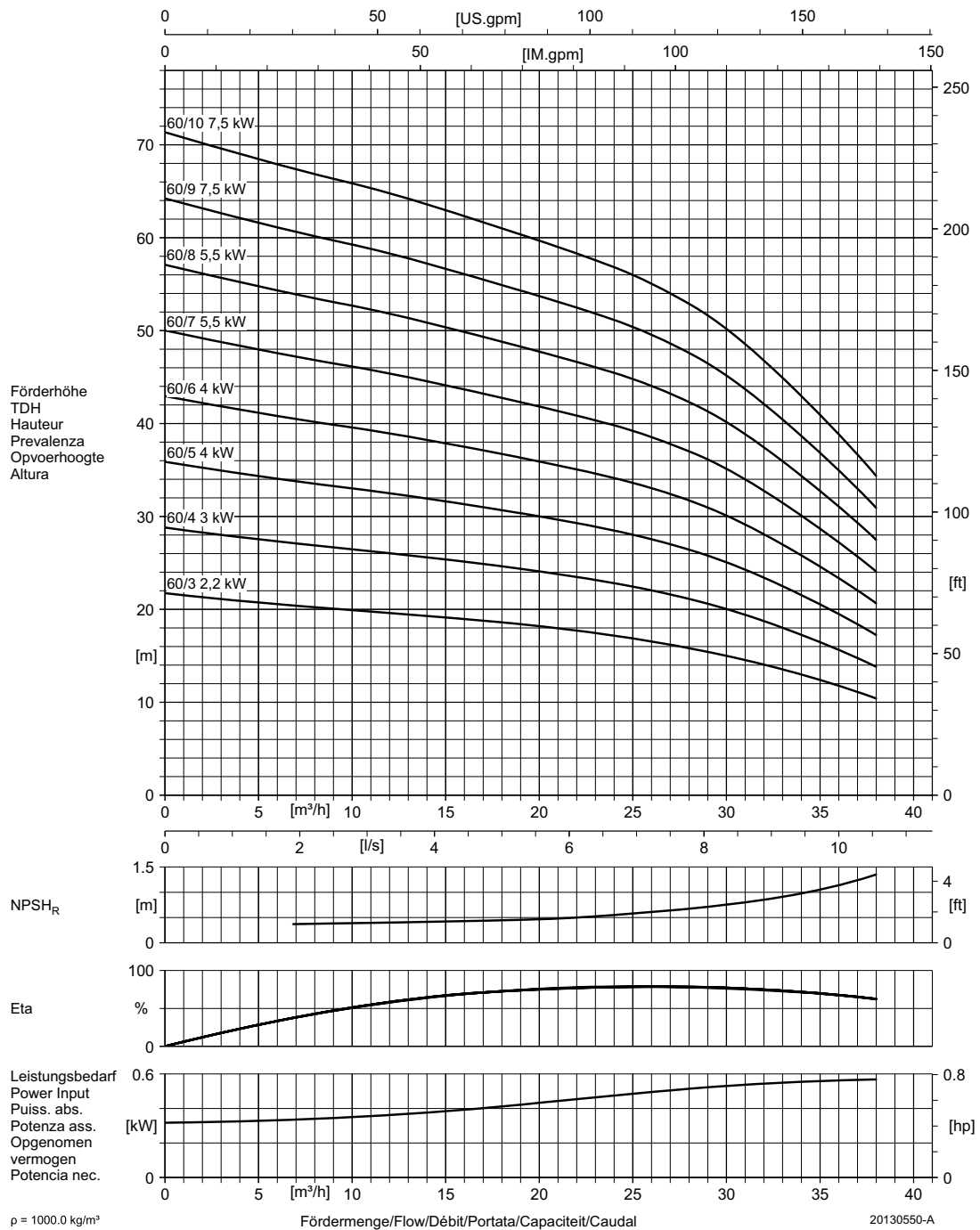

Performance curve DPV(C/S) 60 B - 50Hz - 4 pole



## 2.19 Hydraulic performance curve DPV(C/S) 85 B - 50Hz - 2 pole (2900 rpm)

0222

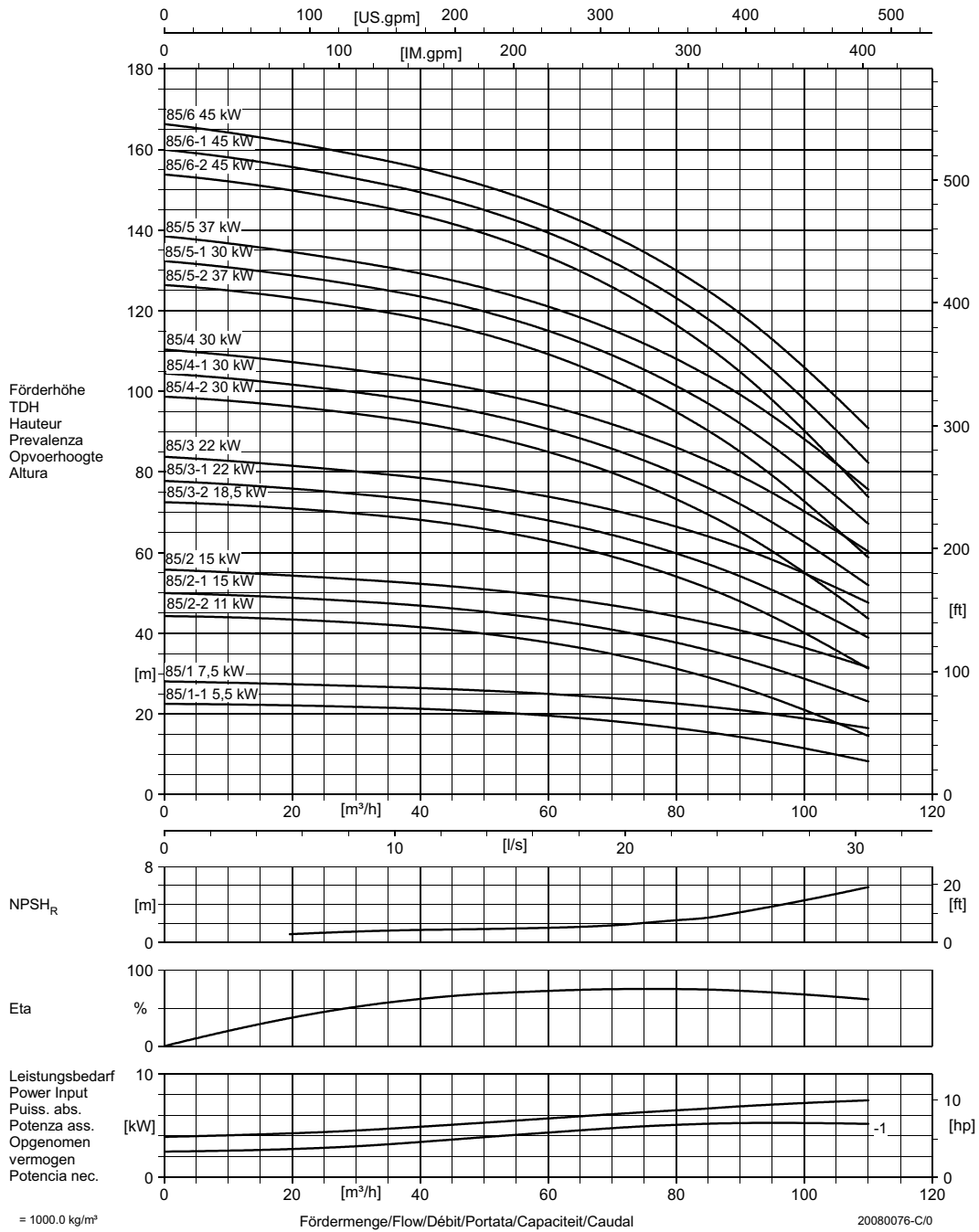

## 2.20 Hydraulic performance curve DPV(C/S) 85 B - 50Hz - 4 pole (1450 rpm)

02229

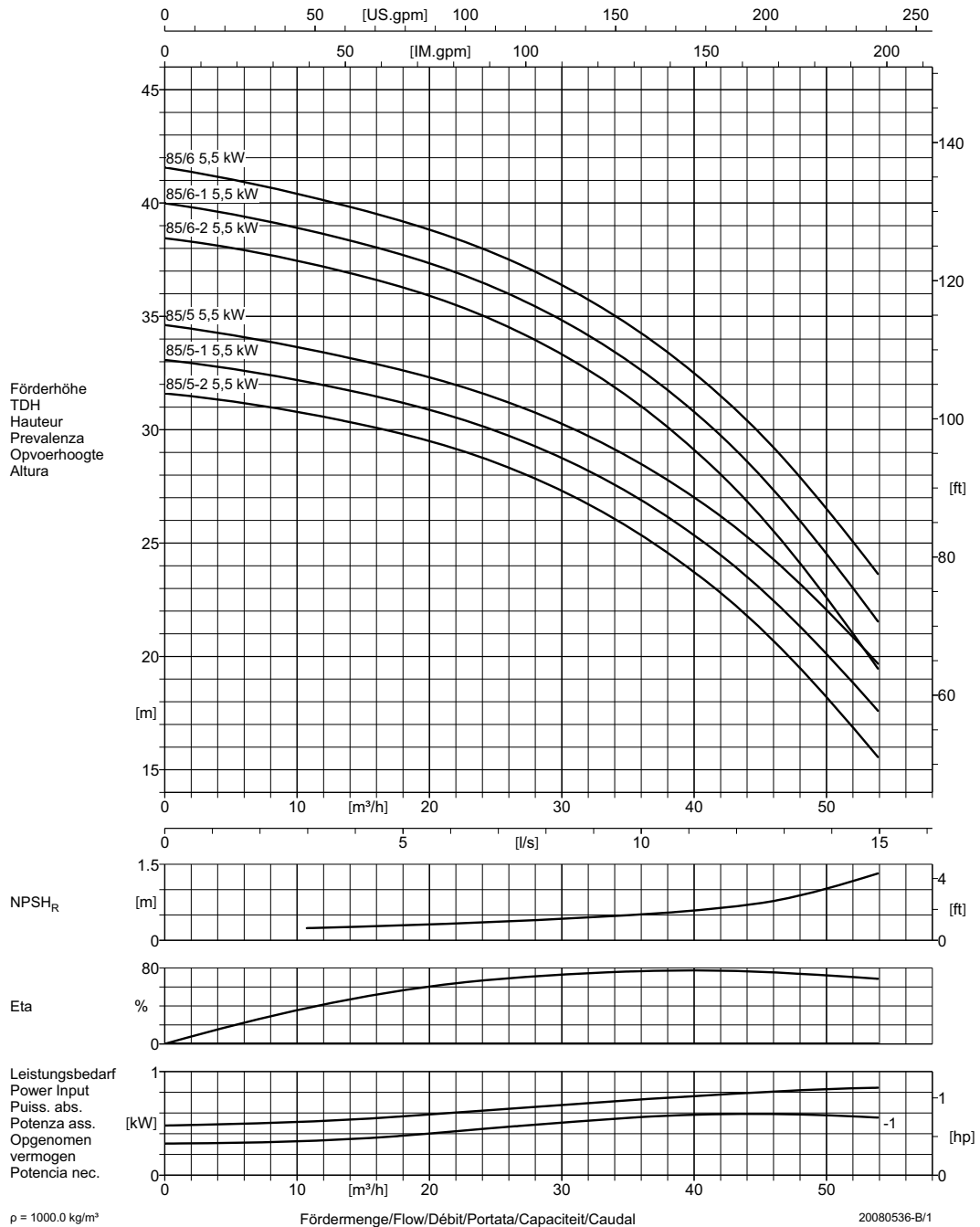

## 2.21 Hydraulic performance curve DPV(C/S) 125 B - 50Hz - 2 pole (2900 rpm)

0222

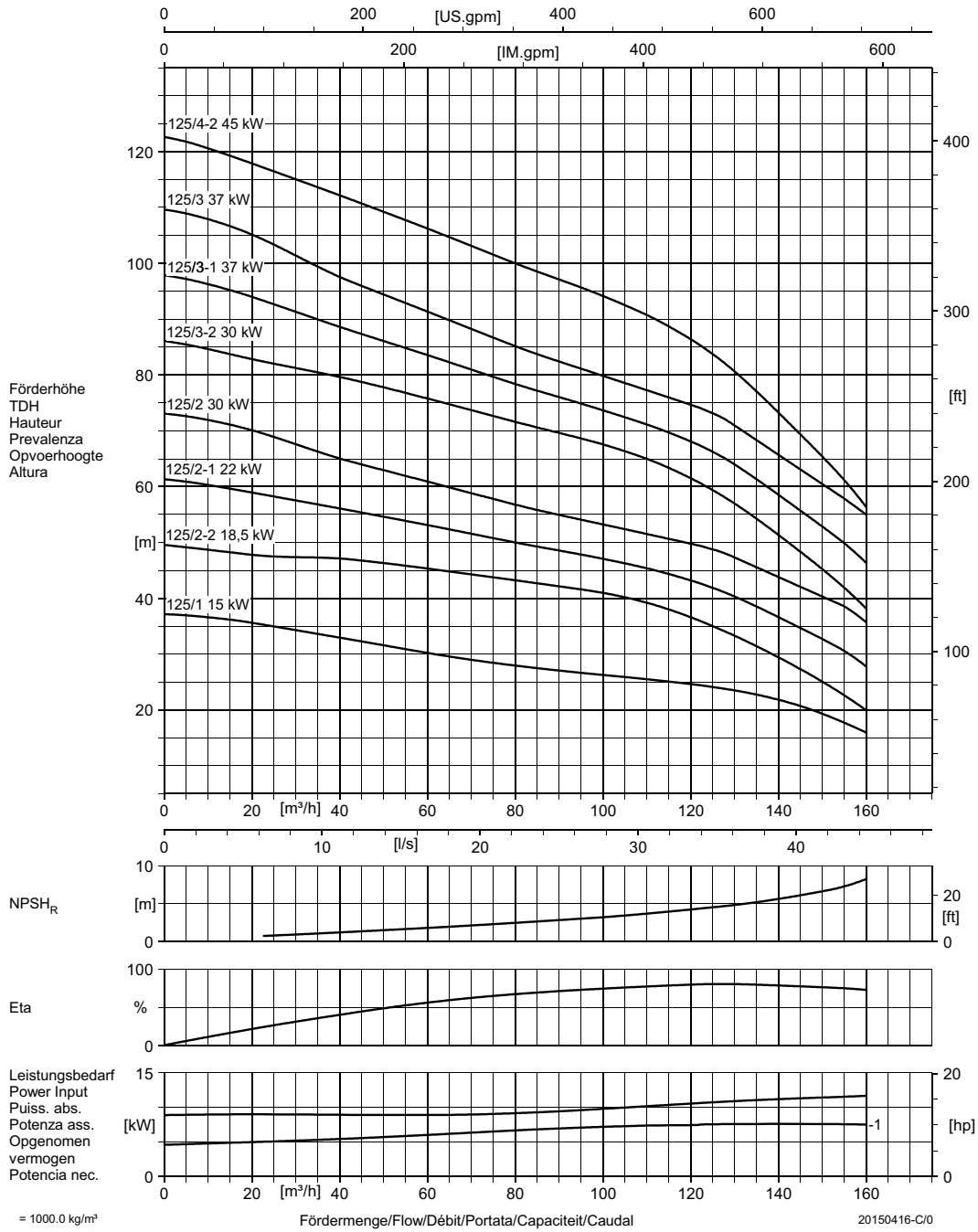

# 3 Low NPSH impeller

## 3.1 General

Low NPSH impeller

For the pump type series DPV(S/C)(F) 2, 4, 6, 10 and 15 it is now possible to have a low NPSH solution as option. This can prevent cavitation in the pump in case of critical inlet conditions.

Cavitation is the process of forming vapour-filled cavities within the liquid in areas where the available pressure has been reduced below a certain critical value. This also happens in case the pressure drops below the vapour pressure of the liquid. When the pressure raises, these cavities will implode to become fluid again. These implosions generate pressure waves which are transmitted to the surfaces of the hydraulic pump parts and can damage the material. This phenomenon is called incipient cavitation and is characterized by a metallic noise produced by the hammering on the material.

## 3.2 Risks of cavitation:

Reduced lifetime of the pump due to damaged parts and unbalanced hydraulics.

Excessive wear of pump parts or motor bearings. Insufficient cooling and/or lubrication of the mechanical seal and pump bearing.

## 3.3 Benefits of using low NPSH impeller:

More suitable in critical inlet conditions.

Easy adaption to non-optimized application parameters.

The suction lift ( $H_p$ ) can be less critical (e.g. the frame height of the de-aerating tank in case of boiler feed can be reduced)

## 3.4 Consequences by using a low NPSH impeller:

No change in pump height or connection.

Slight adjustments on the performance curve, see curves as published on pages 32 to 38.

## 3.5 Calculation of NPSHa

Calculation  $NPSHa > NPSHr + 0,5$   
Check if cavitation can be expected.

$$H_b + H_o + H_p - H_v - H_i > NPSHr + 0,5$$

$H_b$  = barometric pressure in mwc

$H_o$  = over pressure (in case of closed tank) in mwc

$H_p$  = suction lift in mwc

$H_v$  = vapour pressure in mwc

$H_i$  = friction loss in pipe work and accessories in mwc

$NPSHr$  = net positive suction head of the pump

0.5 = safety factor

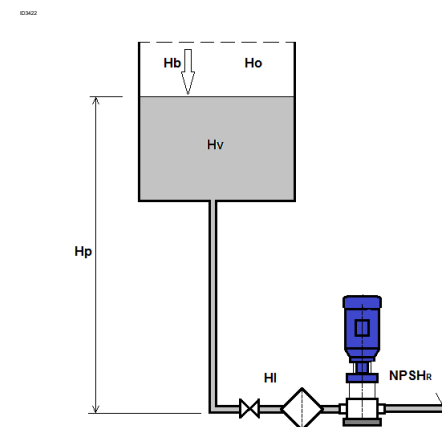

### Calculation NPSHa

Atmospheric pressure	+ 10.3 mwc
Overpressure in degassing tank	+ ..... mwc
Positive height of degassing tank or vessel	+ ..... mwc
Vapour pressure of feed water (see table)in degassing tank in case of boiler feed	- ..... mwc
Loss of pressure in suction piping and strainer	- ..... mwc
Safety factor	- 0.5 mwc
NPSHr at duty point (see pumpcurve)	- ..... mwc
Minimal positive pressure	<hr/> x mwc

If 'x' is positive there is no cavitation to be expected

If 'x' is negative cavitation can be expected, to avoid this the low NPSH impeller could solve this problem. Otherwise one of the other values can be changed so the outcome will be positive.

### Vapour pressure water:

020875

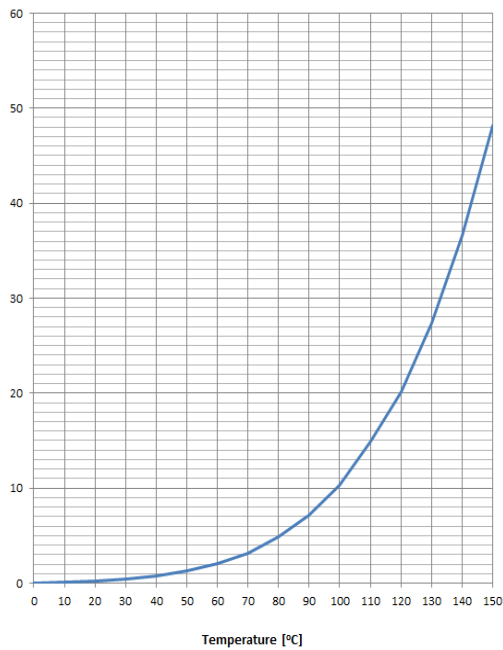

### 3.6 Low NPSH curve DPV(C/S) 2 B - 50Hz - (2900 rpm)

0202

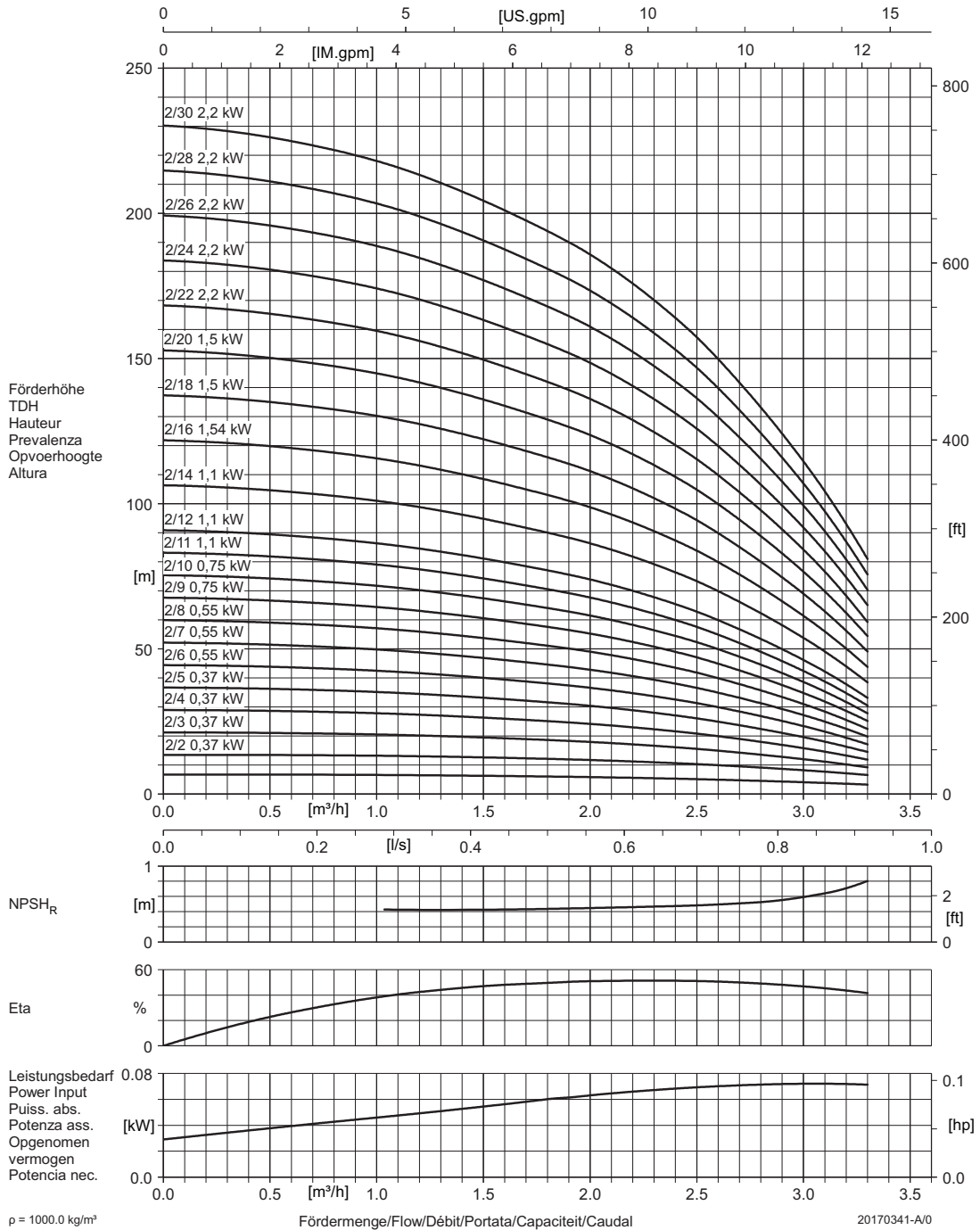

curve DPV(C/S) 2 B - 50Hz - 2 pole



### 3.7 Low NPSH curve DPV(C/S) 4 B - 50Hz - (2900 rpm)

0040

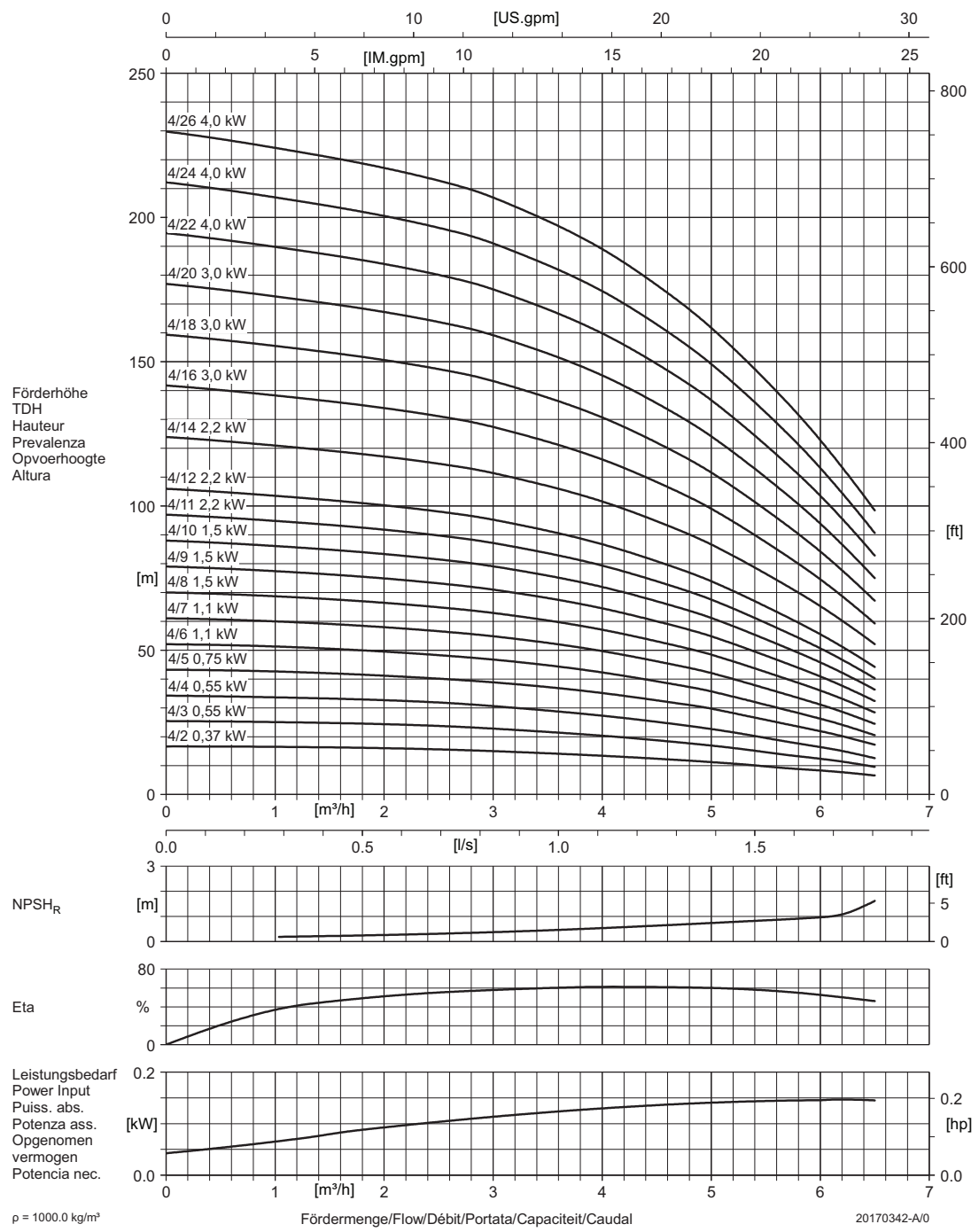



### 3.8 Low NPSH curve DPV(C/S) 6 B - 50Hz - (2900 rpm)

0202

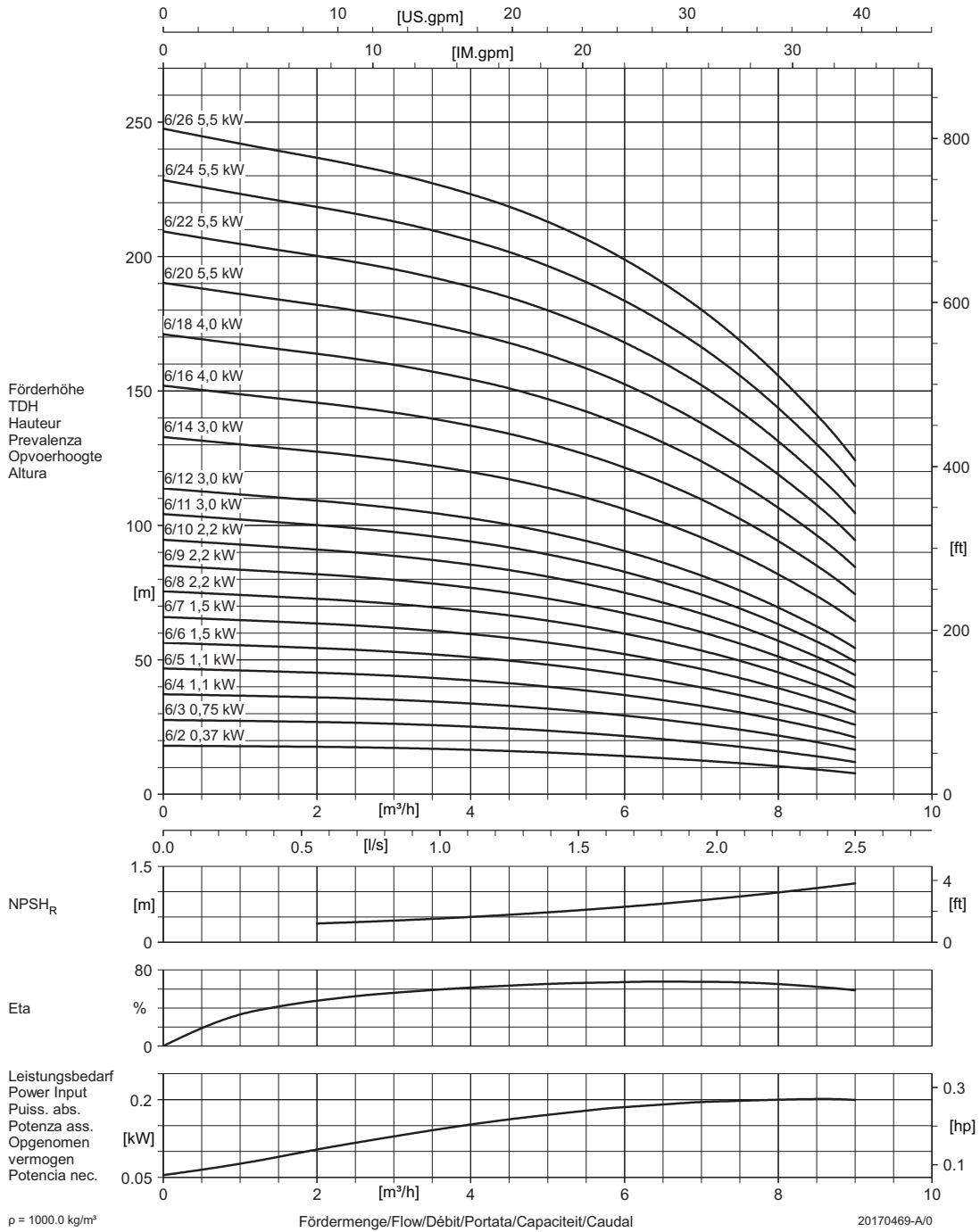

curve DPV(C/S)6 B - 50Hz - 2 pole



### 3.9 Low NPSH curve DPV(C/S) 10 B - 50Hz - (2900 rpm)

0242

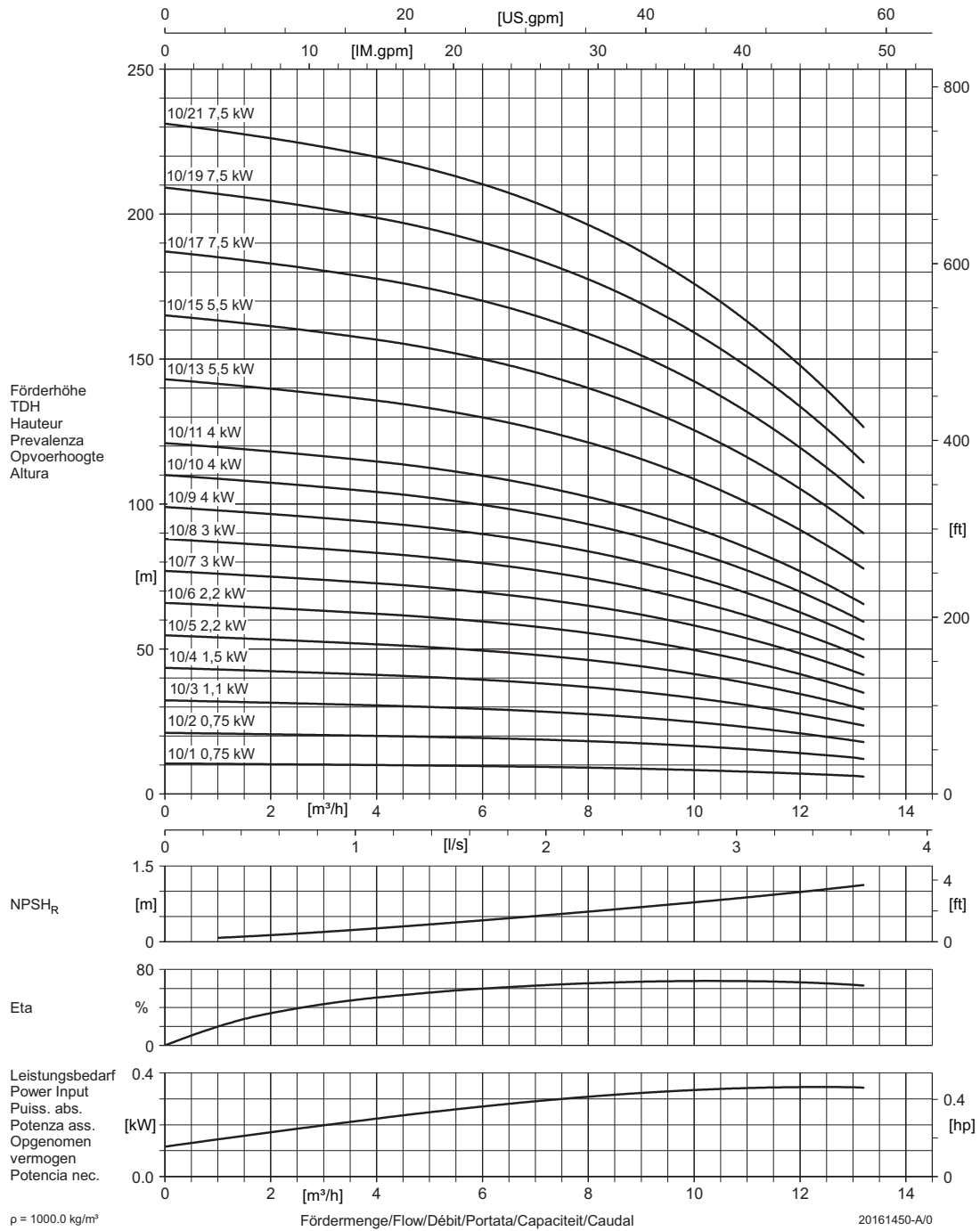

curve DPV(C/S) 10 B - 50Hz - 2 pole

### 3.10 Low NPSH curve DPV(C/S) 10 B - 50Hz - (1450 rpm)

0202

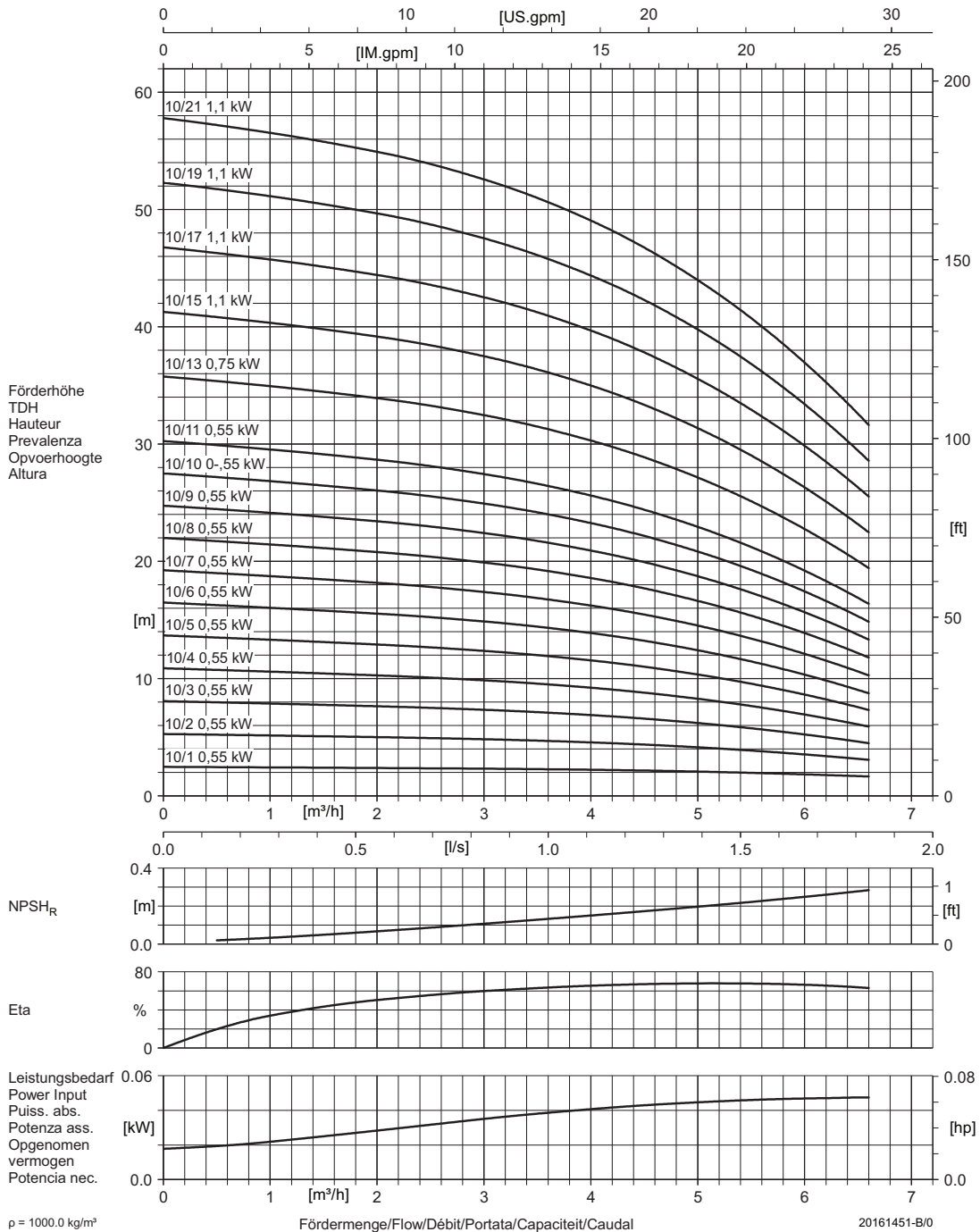

curve DPV(C/S) 10 B - 50Hz - 4 pole



### 3.11 Low NPSH curve DPV(C/S) 15 C - 50Hz - (2900 rpm)

02020

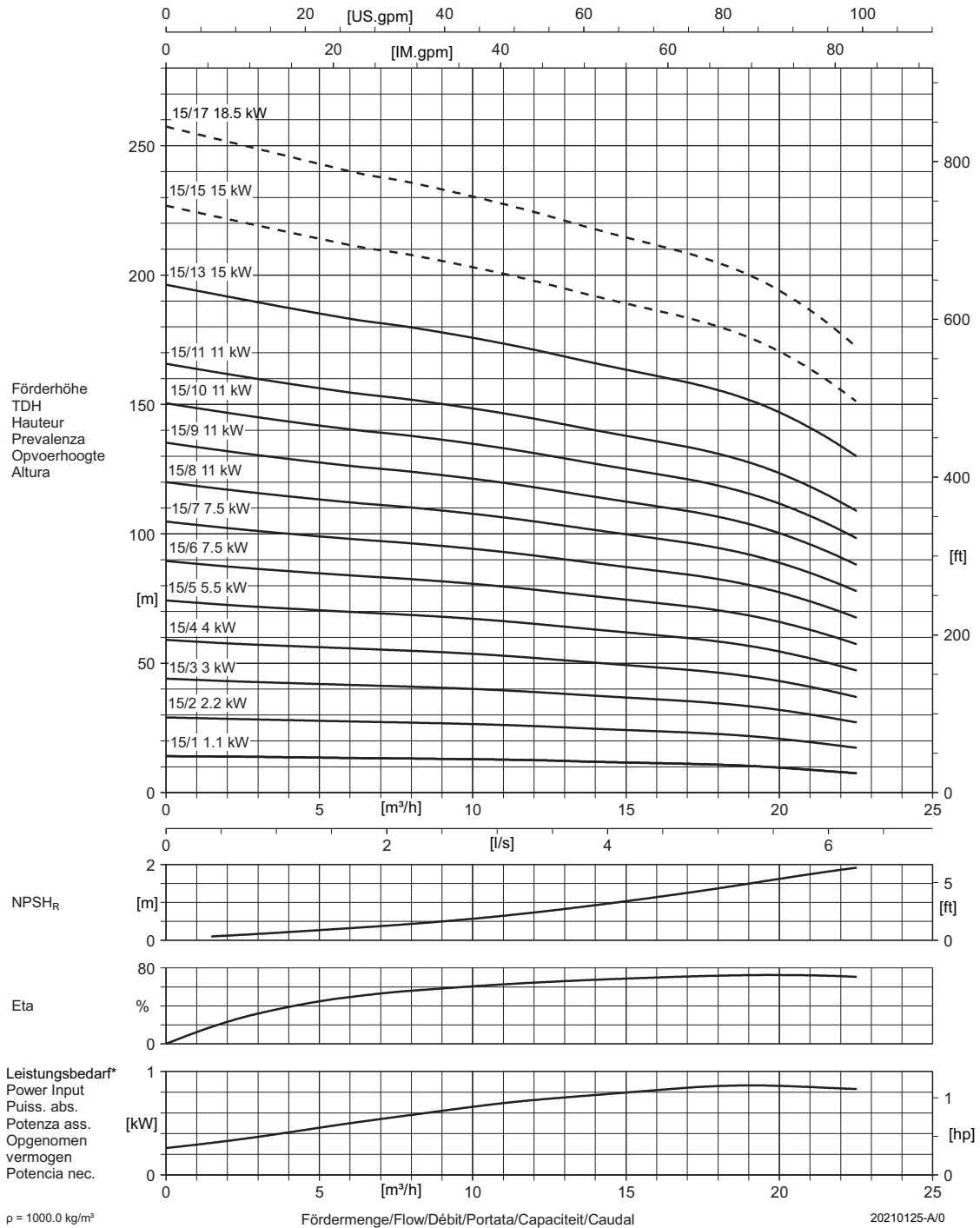

### 3.12 Low NPSH curve DPV(C/S) 15 C - 50Hz - (1450 rpm)

02020

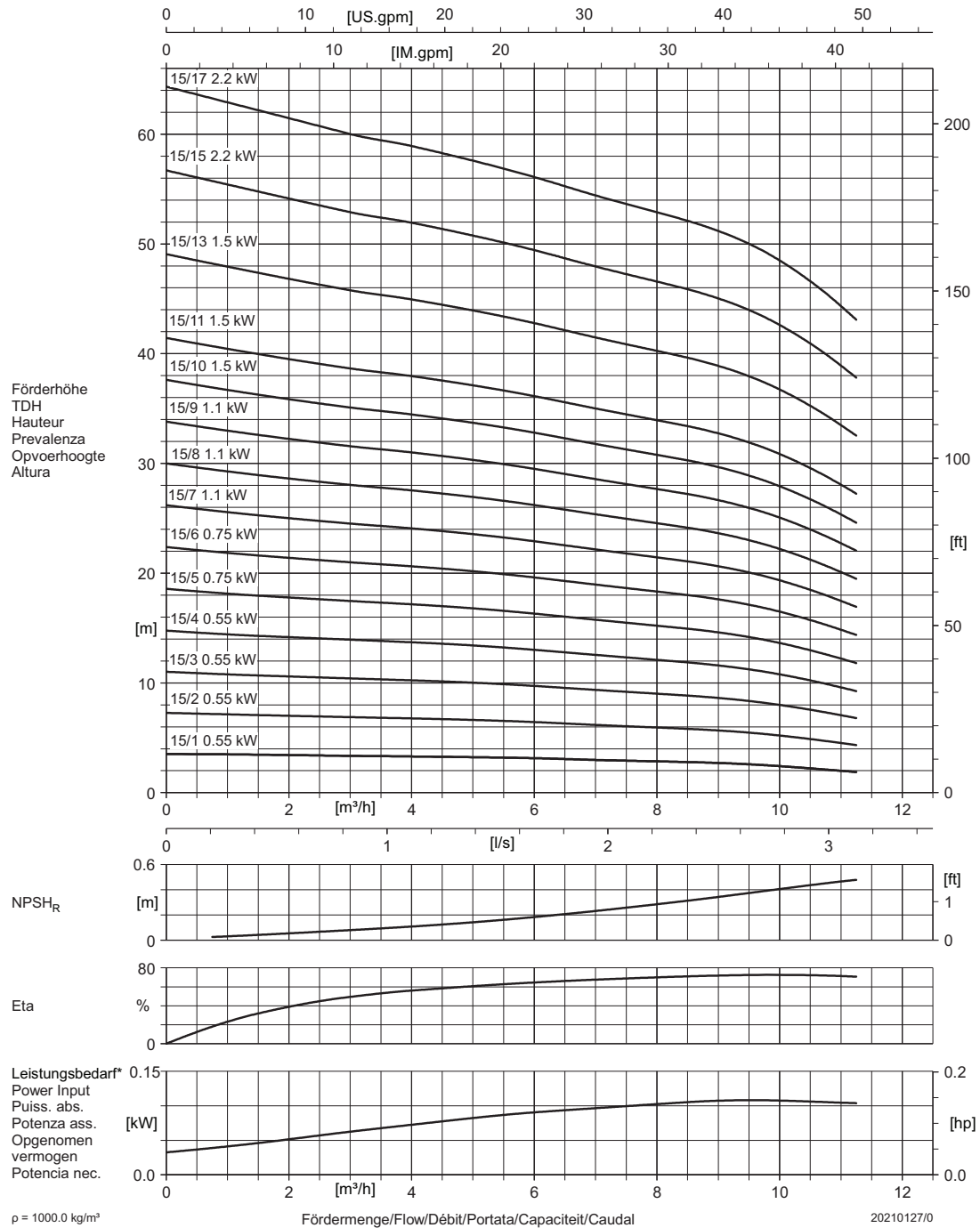

curve DPV(C/S) 15 C - 50Hz - 4 pole



# 4 Dimensions

## 4.1 DPV(C/S) 2 B - 50Hz - 2 pole - DIN

VM CLOSED coupled motor construction type; IM 3619

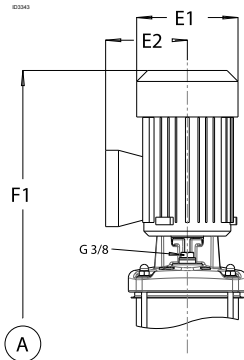

20081033-E

Model	Pressure class	Power [kW]	Motor dimensions			DPVM (-E/V/T)			DPVMF		
			E1 [mm]	E2 [mm]	P [mm]	F1 [mm]	F2 [mm]	Mass [kg]	F1 [mm]	F2 [mm]	Mass [kg]
2/2	PN10	0,37	134	107		420		15	445		20
2/3		0,37	134	107		441		16	466		21
2/4		0,37	134	107		463		16	488		21
2/5		0,37	134	107		484		17	509		21
2/6		0,55	134	107		506		17	531		22

coupled motor construction type; V18

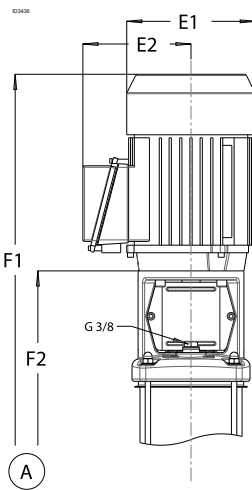

20091216-A/30112009

Model	Pressure class	Power [kW]	Motor dimensions <sup>1</sup>			DPV(S)-E/V/T (E-casing PN16)			DPV(C/S)F		
			E1 [mm]	E2 [mm]	P [mm]	F1 [mm]	F2 [mm]	Mass [kg]	F1 [mm]	F2 [mm]	Mass [kg]
2/2	PN10	0,37	134	107		478	259	18	503	284	22
2/3		0,37	134	107		499	280	18	524	305	23
2/4		0,37	134	107		521	302	18	546	327	23
2/5		0,37	134	107		542	323	19	567	348	24
2/6		0,55	134	107		588	345	19	613	370	24
2/7		0,55	134	107		609	366	20	634	391	25
2/8		0,55	134	107		631	398	20	656	423	25
2/9		0,75	150	115		653	419	27	678	444	32
2/10		0,75	150	115		675	441	27	700	466	32
2/11		1,1	150	115		726	462	28	751	487	32
2/12		1,1	150	115		748	484	28	773	509	33
2/14		PN16	1,1	150	115		791	527	29	816	552
2/16	1,5*		200	148		861	580	36	886	605	40
2/18	1,5*		200	148		904	623	36	929	648	41
2/20	1,5*		200	148		947	666	37	972	691	42
2/22	PN25/40	2,2*	200	148		990	709	45	1015	734	46
2/24		2,2*	200	148		1033	752	46	1058	777	46
2/26		2,2*	200	148		1076	795	46	1101	820	47
2/28		2,2*	200	148		1119	838	47	1144	863	48
2/30		2,2*	200	148		1162	881	64	1187	906	64

- All motor dimensions are only valid for Cantoni motors with efficiency class IE3 (motor power  $\geq 0,75$  kW).  
\*Dimensions of IE3-v2 motor.

	<p><b>DPV E Male thread -</b>  With non return valve insert at discharge side and pressure measurement plug at upstream side  Norm: G EN ISO 228  Size: G 6/4  Pressure Class: PN16  Option: Base plate in Cast SS 1.4308</p>
	<p><b>DPV (S)</b>  Counter flange with female thread included  DPV: Cathodic coated cast iron  DPVS: Cast Stainless steel 1.4408  Norm: G EN ISO 228  Size: G1  Pressure Class: PN16  Option: SS 1.4308 flange and base plate</p>
	<p><b>DPV (S) V Victaulic</b>  Norm: -  Size: 42,2  Pressure Class: PN40  Option: Base plate in cast SS 1.4308</p>
	<p><b>DPV (S) T Tri-Clamp</b>  Norm: 32676  Size: DN32  Pressure Class: PN40  Option: Base plate in cast SS 1.4308</p>
	<p><b>DPV C F Cast iron flange</b>  Norm: EN 1092-1/1092-2  Size: NW25  Pressure Class: PN40</p>
	<p><b>DPV (S) F Loose plate flange</b>  Cathodic coated loose plate flange  Norm: EN 1092-1/1092-2  Size: NW25  Pressure Class: PN40  Option: Loose plate flange (PN25) and/or base plate in cast SS 1.4308</p>



## 4.2 DPV(C/S) 4 B - 50Hz - 2 pole - DIN

VM CLOSED coupled motor construction type; IM 3619

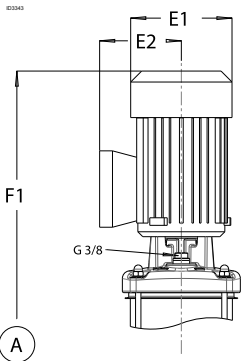

Model	Pressure class	Power [kW]	Motor dimensions			DPVM(-E/V/T)			DPVMF		
			E1 [mm]	E2 [mm]	P [mm]	F1 [mm]	F2 [mm]	Mass [kg]	F1 [mm]	F2 [mm]	Mass [kg]
4/2	PN10	0,37	134	107		420		15	453		20
4/3		0,55	134	107		441		16	466		21
4/4		0,55	134	107		463		16	488		21
4/5		0,75	150	115		528		23	553		27
4/6		1,1	150	115		550		23	573		28

20081033-E

coupled motor construction type; V18

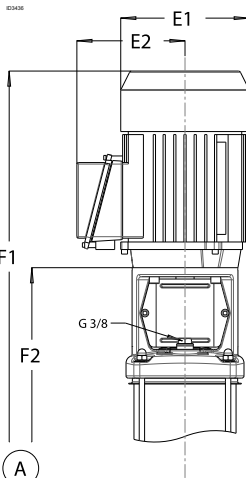

Model	Pressure class	Power [kW]	Motor dimensions <sup>1</sup>			DPV(S)-(-E/V/T) (E-casing PN16)			DPV(C/S)F		
			E1 [mm]	E2 [mm]	P [mm]	F1 [mm]	F2 [mm]	Mass [kg]	F1 [mm]	F2 [mm]	Mass [kg]
4/2	PN10	0,37	134	107		478	259	18	503	284	22
4/3		0,55	134	107		523	280	18	548	305	23
4/4		0,55	134	107		545	302	19	570	327	23
4/5		0,75	150	115		567	333	25	592	358	30
4/6		1,1	150	115		619	355	26	644	380	30
4/7		1,1	150	115		640	376	26	665	401	31
4/8		1,5*	200	148		689	408	32	714	433	37
4/9		1,5*	200	148		710	429	33	735	454	37
4/10		1,5*	200	148		732	451	33	757	476	38
4/11		2,2*	200	148		753	472	34	778	497	39
4/12		PN16	2,2*	200	148		775	494	35	800	519
4/14	2,2*		200	148		818	537	36	843	562	41
4/16	3*		215	157		907	590	47	932	615	52
4/18	PN25/40	3*	215	157		950	633	52	975	658	53
4/20		3*	215	157		993	676	53	1018	701	53
4/22		4*	248	168		1075	719	60	1100	744	61
4/24		4*	248	168		1118	762	61	1143	787	62
4/26		4*	248	168		1161	805	61	1186	830	62

20091216-A/30112009

1. All motor dimensions are only valid for Cantoni motors with efficiency class IE3 (motor power  $\geq 0,75$  kW).

\*Dimensions of IE3-v2 motor.



	<p><b>DPV E Male thread -</b>  With non return valve insert at discharge side and pressure measurement plug at upstream side  Norm: G EN ISO 228  Size: G 6/4  Pressure Class: PN16  Option: Base plate in cast SS 1.4308</p>
	<p><b>DPV (S)</b>  Counter flange with female thread included  DPV: Cataphoric coated cast iron  DPVS: Cast Stainless steel 1.4408  Norm: G EN ISO 228  Size: G1  Pressure Class: PN16  Option: Base plate &amp; flange in SS 1.4308</p>
	<p><b>DPV (S) V Victaulic</b>  Norm: -  Size: 42,2  Pressure Class: PN40  Option: Base plate in cast SS 1.4308</p>
	<p><b>DPV (S) T Tri-Clamp</b>  Norm: 32676  Size: DN32  Pressure Class: PN40  Option: Base plate in cast SS 1.4308</p>
	<p><b>DPV C F Cast iron flange</b>  Norm: EN 1092-1/1092-2  Size: NW25  Pressure Class: PN40</p>
	<p><b>DPV (S) F Loose plate flange</b>  Cataphoric coated loose plate flange  Norm: EN 1092-1/1092-2  Size: NW25  Pressure Class: PN40  Option: Loose plate flange (PN25) and/or base plate in cast SS 1.4308</p>

### 4.3 DPV(C/S) 6 B - 50Hz - 2 pole - DIN

VM CLOSED coupled motor construction type; IM 3619

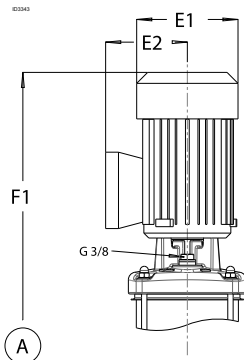

20081033-E

Model	Pressure class	Power [kW]	Motor dimensions			DPVM(-E/V/T)			DPVMF		
			E1 [mm]	E2 [mm]	P [mm]	F1 [mm]	F2 [mm]	Mass [kg]	F1 [mm]	F2 [mm]	Mass [kg]
6/2	PN10	0,37	134	107		427		16	452		24
6/3		0,75	150	115		496		22	521		30
6/4		1,1	150	115		521		23	546		31
6/5		1,1	150	115		546		23	571		31

coupled motor construction type; V18

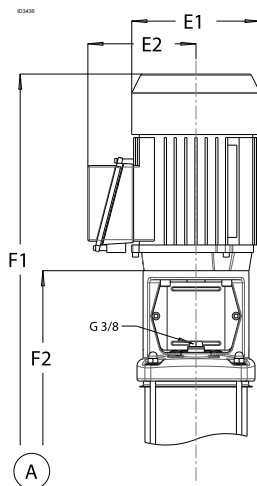

20091216-A/30112009

Model	Pressure class	Power [kW]	Motor dimensions <sup>1</sup>			DPV(S)(-E/V/T) (E-casing PN16)			DPV(C/S)F		
			E1 [mm]	E2 [mm]	P [mm]	F1 [mm]	F2 [mm]	Mass [kg]	F1 [mm]	F2 [mm]	Mass [kg]
6/2	PN10	0,37	134	107		485	266	18	510	291	26
6/3		0,75	150	115		535	301	25	560	326	31
6/4		1,1	150	115		590	326	25	615	351	31
6/5		1,1	150	115		615	351	26	640	376	32
6/6		1,5*	200	148		667	386	32	692	411	38
6/7		1,5*	200	148		692	411	32	717	436	38
6/8		2,2*	200	148		717	436	34	742	461	40
6/9		2,2*	200	148		742	461	34	767	486	41
6/10		2,2*	200	148		767	486	35	792	511	41
6/11		PN16	3*	215	157		838	521	45	863	546
6/12	3*		215	157		863	546	46	888	571	52
6/14	3*		215	157		913	596	47	938	621	53
6/16	4*		248	168		1002	646	51	1027	671	61
6/18	PN25/40	4*	248	168		1052	696	61	1077	721	62

coupled motor construction type; V1

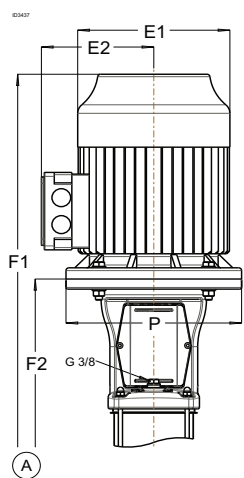

20091217

Model	Pressure class	Power [kW]	Motor dimensions <sup>1</sup>			DPV(S) (V/T)			DPV(C/S)F		
			E1 [mm]	E2 [mm]	P [mm]	F1 [mm]	F2 [mm]	Mass [kg]	F1 [mm]	F2 [mm]	Mass [kg]
6/20	PN25/40	5,5	288	197	300	1254	822	96	1279	847	97
6/22		5,5	288	197	300	1304	872	97	1329	897	98
6/24		5,5	288	197	300	1354	922	98	1379	947	99
6/26		5,5	288	197	300	1404	972	99	1429	997	100

1. All motor dimensions are only valid for Cantoni motors with efficiency class IE3 (motor power  $\geq 0,75$  kW). \*Dimensions of IE3-v2 motor.

	<p><b>DPV E Male thread -</b>  With non return valve insert at discharge side and pressure measurement plug at upstream side  Norm: G EN ISO 228  Size: G 6/4  Pressure Class: PN16  Option: Base plate in cast SS 1.4308</p>
	<p><b>DPV (S)</b>  Counter flange with female thread included  DPV: Cathodic coated cast iron  DPVS: Cast Stainless steel 1.4408  Norm: G EN ISO 228  Size: G 5/4  Pressure Class: PN16  Option: Flange and base plate in SS1.4308</p>
	<p><b>DPV (S) V Victaulic</b>  Norm: -  Size: 42,2  Pressure Class: PN40  Option: Base plate in SS 1.4308</p>
	<p><b>DPV (S) T Tri-Clamp</b>  Norm: 32676  Size: DN32  Pressure Class: PN40  Option: Baseplate in cast SS 1.4308</p>
	<p><b>DPV C F Cast iron flange</b>  Norm: EN 1092-1/1092-2  Size: NW32  Pressure Class: PN40</p>
	<p><b>DPV (S) F Loose plate flange</b>  Cathodic coated loose plate flange  Norm: EN 1092-1/1092-2  Size: NW32  Pressure Class: PN40  Option: Loose plate flange (PN25) and/or base plate in cast SS 1.4308</p>

## 4.4 DPV(C/S) 10 B - 50Hz - 2 pole - DIN

coupled motor construction type; V18

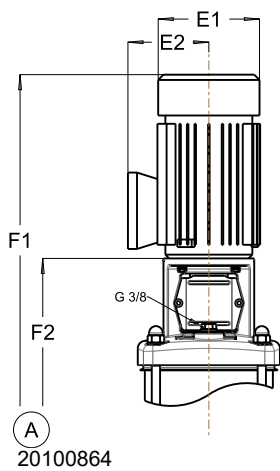

Model	Pressure class	Power [kW]	Motor dimensions <sup>1</sup>			DPV(S)(-E/V/T) (E-casing PN16)			DPV(C/S)F		
			E1 [mm]	E2 [mm]	P [mm]	F1 [mm]	F2 [mm]	Mass [kg]	F1 [mm]	F2 [mm]	Mass [kg]
10/1	PN10	0,75	150	115		580	346	32	621	346	36
10/2		0,75	150	115		580	346	33	621	346	36
10/3		1,1	150	115		636	372	36	636	372	39
10/4		1,5*	200	148		690	409	41	690	409	45
10/5		2,2*	200	148		717	435	45	717	435	48
10/6		2,2*	200	148		743	462	45	743	462	49
10/7		3*	215	157		816	498	54	816	498	58
10/8		3*	215	157		842	525	55	842	525	59
10/9	PN16	4*	248	168		908	551	62	908	551	65
10/10		4*	248	168		934	578	63	934	578	66
10/11		4*	248	168		961	604	64	961	604	67

coupled motor construction type; V1

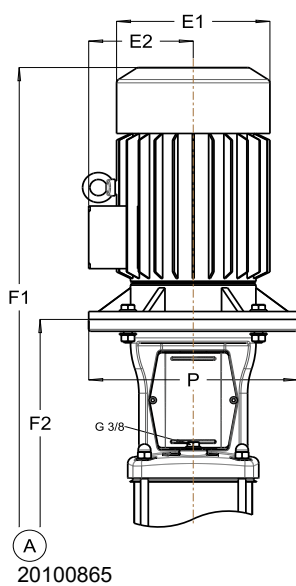

Model	Pressure class	Power [kW]	Motor dimensions <sup>1</sup>			DPV(S)(-V/T)			DPV(C/S)F		
			E1 [mm]	E2 [mm]	P [mm]	F1 [mm]	F2 [mm]	Mass [kg]	F1 [mm]	F2 [mm]	Mass [kg]
10/13	PN16	5,5	266	178	300	1169	737	104	1169	737	108
10/15	PN25/40	5,5	266	178	300	1222	790	108	1222	790	112
10/17		7,5	266	178	300	1275	843	116	1275	843	118
10/19		7,5	266	178	300	1328	896	118	1328	896	120
10/21		7,5	266	178	300	1381	949	120	1381	949	122

1. All motor dimensions are only valid for Cantoni motors with efficiency class IE3 (motor power  $\geq 0,75$  kW). \*Dimensions of IE3-v2 motor.

	<p><b>DPV E Male thread -</b>          With non return valve insert at discharge side and pressure measurement plug at upstream side          Norm: G EN ISO 228          Size: G 2          Pressure Class: PN16          Option: Base plate in cast SS 1.4308</p>
	<p><b>DPV (S)</b>          Counter flange with female thread included          DPV: Cathodic coated cast iron          DPVS: Cast Stainless steel 1.4408          Norm: G EN ISO 228          Size: G 6/4          Pressure Class: PN16          Option: Flange and base plate in SS1.4308</p>
	<p><b>DPV (S) V Victaulic</b>          Norm: -          Size: 60,3          Pressure Class: PN40          Option: Base plate in SS 1.4308</p>
	<p><b>DPV (S) T Tri-Clamp</b>          Norm: 32676          Size: Ø64          Pressure Class: PN40          Option: Baseplate in cast SS 1.4308</p>
	<p><b>DPV C F Cast iron flange</b>          Norm: EN 1092-1/1092-2          Size: NW40          Pressure Class: PN40</p>
	<p><b>DPV (S) F Loose plate flange</b>          Cathodic coated loose plate flange          Norm: EN 1092-1/1092-2          Size: NW40          Pressure Class: PN40          Option: Loose plate flange (PN25) and/or base plate in cast SS 1.4308</p>

## 4.5 DPV(C/S) 10 B - 50Hz - 4 pole - DIN

coupled motor construction type; V18

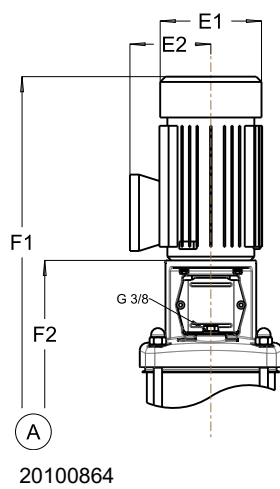

Model	Pressure class	Power [kW]	Motor dimensions <sup>1</sup>			DPV(S)(-E/V/T)			DPV(C/S)F		
			E1 [mm]	E2 [mm]	P [mm]	F1 [mm]	F2 [mm]	Mass [kg]	F1 [mm]	F2 [mm]	Mass [kg]
10/1	PN10	0,55	150	115		603	346	35	603	346	38
10/2		0,55	150	115		603	346	35	603	346	38
10/3		0,55	150	115		629	372	36	629	372	39
10/4		0,55	150	115		656	399	37	656	399	41
10/5		0,55	150	115		682	425	38	682	425	42
10/6		0,55	150	115		709	452	39	709	452	43
10/7		0,55	150	115		735	478	40	735	478	44
10/8		0,55	150	115		762	505	41	762	505	45
10/9		0,55	150	115		788	531	43	788	531	46
10/10		0,55	150	115		815	558	44	815	558	47
10/11		0,55	150	115		841	584	45	841	584	48
10/13		0,75	150	115		957	672	62	957	672	65
10/15		1,1	180	145		985	700	67	985	700	71
10/17		1,1	180	145		1038	753	71	1038	753	73
10/19		1,1	180	145		1091	806	73	1091	806	75
10/21		1,1	180	145		1144	859	75	1144	859	77

1. All motor dimensions are only valid for Wonder motors with efficiency class IE3 (motor power  $\geq 0,75$ kW).

	<p><b>DPV E Male thread -</b>          With non return valve insert at discharge side and pressure measurement plug at upstream side          Norm: G EN ISO 228          Size: G 2          Pressure Class: PN16          Option: Base plate in cast SS 1.4308</p>	<p>20090654</p>
	<p><b>DPV (S)</b>          Counter flange with female thread included          DPV: Cataphoric coated cast iron          DPVS: Cast Stainless steel 1.4408          Norm: G EN ISO 228          Size: G 6/4          Pressure Class: PN16          Option: Flange and base plate in SS1.4308</p>	<p>20090653</p>
	<p><b>DPV (S) V Victaulic</b>          Norm: -          Size: 60,3          Pressure Class: PN40          Option: Base plate in SS 1.4308</p>	<p>20090650</p>
	<p><b>DPV (S) T Tri-Clamp</b>          Norm: 32676          Size: Ø64          Pressure Class: PN40          Option: Baseplate in cast SS 1.4308</p>	<p>20090659</p>
	<p><b>DPV C F Cast iron flange</b>          Norm: EN 1092-1/1092-2          Size: NW40          Pressure Class: PN40</p>	<p>20090656</p>
	<p><b>DPV (S) F Loose plate flange</b>          Cataphoric coated loose plate flange          Norm: EN 1092-1/1092-2          Size: NW40          Pressure Class: PN40          Option: Loose plate flange (PN25) and/or base plate in cast SS 1.4308</p>	<p>20090655</p>

## 4.6 DPV(C/S) 15 C - 50Hz - 2 pole - DIN

### 4.7 coupled motor construction type; V18

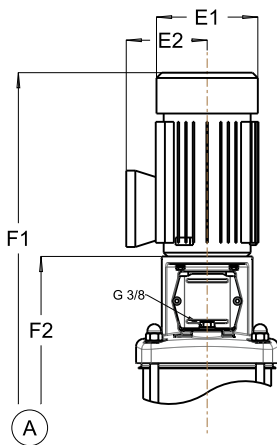

20100864

Model	Pressure class	Power [kW]	Motor dimensio			DPV(S)			DPV(C/S)F - DPV(S)(V/T)		
			E1 [mm]	E2 [mm]	P [mm]	F1 [mm]	F2 [mm]	Massa [kg]	F1 [mm]	F2 [mm]	Massa [kg]
15/1	PN10	1,1	157	133		619	362	33	629	372	36
15/2		2,2	200	148		653	372	43	663	382	46
15/3		3	215	157		740	423	52	750	433	55
15/4		4	248	168		820	464	62	830	474	65

### coupled motor construction type; V1

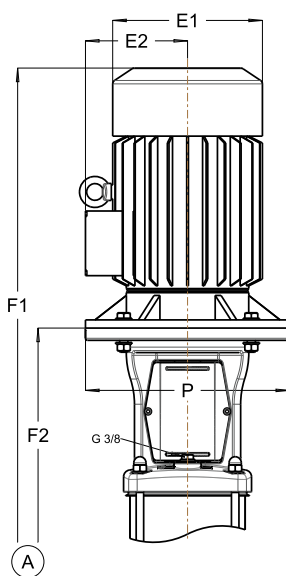

20100865

Model	Pressure class	Power [kW]	Motor dimensions <sup>1</sup>			DPV(S)			DPV(C/S)F - DPV(S)(V/T)		
			E1 [mm]	E2 [mm]	P [mm]	F1 [mm]	F2 [mm]	Massa [kg]	F1 [mm]	F2 [mm]	Massa [kg]
15/5	PN10	5,5	288	197	300	1017	585	102	1027	595	105
15/6		5,5 <sup>2</sup>	288	197	300	1058	626	103	1068	636	105
15/6		7,5	288	197	300	1058	626	103	1068	636	105
15/7	PN16	7,5	288	197	300	1099	667	104	1109	677	107
15/8		7,5 <sup>2</sup>	288	197	300	1170	738	135	1180	748	138
15/8		11	340	223	350	1271	738	183	1281	748	186
15/9		11	340	223	350	1322	779	188	1322	789	191
15/10		11	340	223	350	1353	820	190	1363	830	193
15/11	PN25	11	340	223	350				1404	871	194
15/13		15	340	223	350				1486	953	224
15/15		15	340	223	350				1568	1035	227
15/17		18,5	340	223	350				1650	1117	244

1. All motor dimensions are only valid for Cantoni motors with efficiency class IE3 (motor power  $\geq 0,75$  kW).
2. Decreased power



	<p><b>DPV (S)</b>  Counter flange with female thread included  DPV: Cataphoric coated cast iron  DPVS: Cast Stainless steel 1.4408  Norm: G EN ISO 228  Size: G 2  Pressure Class: PN16  Option: Flange and base plate in SS1.4308</p>
	<p><b>DPV (S) V Victaulic</b>  Norm: -  Size: 60,3  Pressure Class: PN40  Option: Base plate in SS 1.4308</p>
	<p><b>DPV (S) T Tri-Clamp</b>  Norm: 32676  Size: Ø64  Pressure Class: PN40  Option: Baseplate in cast SS 1.4308</p>
	<p><b>DPV C F Cast iron flange</b>  Norm: EN 1092-1/1092-2  Size: NW50  Pressure Class: PN40</p>
	<p><b>DPV (S) F Loose plate flange</b>  Cataphoric coated loose plate flange  Norm: EN 1092-1/1092-2  Size: NW50  Pressure Class: PN40  Option: Loose plate flange (PN25) and/or base plate in cast SS 1.4308</p>

## 4.8 DPV(C/S) 15 C - 50Hz - 4 pole - DIN

coupled motor construction type; V18

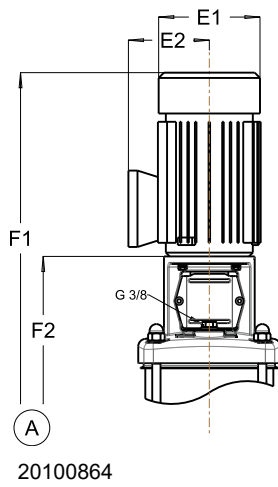

Model	Pressure class	Power [kW]	Motor dimensions <sup>1</sup>			DPV(S)			DPV(C/S)F - DPV(S)V/T		
			E1 [mm]	E2 [mm]	P [mm]	F1 [mm]	F2 [mm]	Massa [kg]	F1 [mm]	F2 [mm]	Massa [kg]
15/1	PN10	0,55	157	112		619	362	32	629	372	36
15/2		0,55	157	112		619	362	33	629	372	37
15/3		0,55	157	112		660	403	35	670	413	38
15/4		0,55	157	112		701	444	36	711	454	39
15/5		0,75	157	133		780	485	43	790	495	46
15/6		0,75	157	133		821	526	44	831	536	47
15/7		1,1	180	145		852	577	48	862	587	51
15/8		1,1	180	145		893	618	67	903	628	70
15/9		1,1	180	145		934	659	72	944	669	75
15/10		1,5	180	145		1000	700	76	1010	710	79
15/11		1,5	180	145		1041	741	77	1051	751	80
15/13		1,5	180	145		1123	823	97	1133	833	100
15/15		2,2	200	155		1233	915	108	1243	925	111
15/17		2,2	200	155		1315	997	116	1325	1007	119

1. All motor dimensions are only valid for Cantoni motors with efficiency class IE3 (motor power  $\geq 0,75$ kW).

	<p><b>DPV E Male thread -</b>          With non return valve insert at discharge side and pressure measurement plug at upstream side          Norm: G EN ISO 228          Size: G 2          Pressure Class: PN16          Option: Base plate in cast SS 1.4308</p>
	<p><b>DPV (S)</b>          Counter flange with female thread included          DPV: Cathodic coated cast iron          DPVS: Cast Stainless steel 1.4408          Norm: G EN ISO 228          Size: G 2          Pressure Class: PN16          Option: Flange and base plate in SS1.4308</p>
	<p><b>DPV (S) V Victaulic</b>          Norm: -          Size: 60,3          Pressure Class: PN40          Option: Base plate in SS 1.4308</p>
	<p><b>DPV (S) T Tri-Clamp</b>          Norm: 32676          Size: Ø64          Pressure Class: PN40          Option: Baseplate in cast SS 1.4308</p>
	<p><b>DPV C F Cast iron flange</b>          Norm: EN 1092-1/1092-2          Size: NW50          Pressure Class: PN40</p>
	<p><b>DPV (S) F Loose plate flange</b>          Cathodic coated loose plate flange          Norm: EN 1092-1/1092-2          Size: NW50          Pressure Class: PN40          Option: Loose plate flange (PN25) and/or base plate in cast SS 1.4308</p>



## 4.9 DPV(C/S) 25 B - 50Hz - 2 pole - DIN

coupled motor construction type; V18

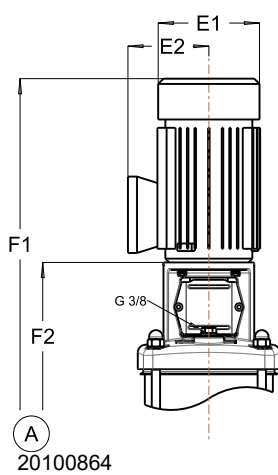

Model	Pressure class	Power [kW]	Motor dimensions <sup>1</sup>			DPV(C/S)F		
			E1 [mm]	E2 [mm]	P [mm]	F1 [mm]	F2 [mm]	Mass [kg]
25/1	PN10	2,2*	200	148		689	408	70
25/2		4*	248	168		834	478	85

\*Dimensions of IE3-v2 motor.

coupled motor construction type; V1

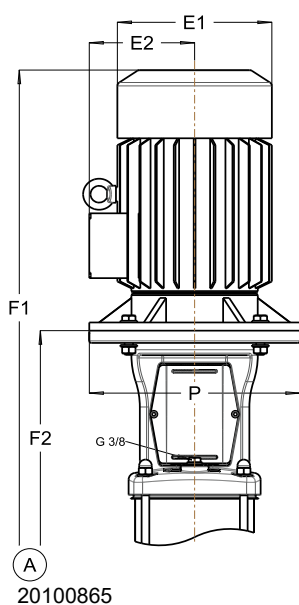

Model	Pressure class	Power [kW]	Motor dimensions <sup>1</sup>			DPV(C/S)F		
			E1 [mm]	E2 [mm]	P [mm]	F1 [mm]	F2 [mm]	Mass [kg]
25/3	PN10	5,5	288	197	300	1066	634	114
25/4		7,5	288	197	300	1131	699	121
25/5	PN16	11	340	223	350	1327	794	203
25/6		11	340	223	350	1392	859	206
25/7		15	340	223	350	1457	924	218
25/8	PN25	15	340	223	350	1522	989	231
25/9		15	340	223	350	1587	1054	233
25/10		18,5	340	223	350	1652	1119	253
25/11		18,5	340	223	350	1717	1184	256
25/12		22	360	234	350	1897	1249	294

1. All motor dimensions are only valid for Cantoni motors with efficiency class IE3 (motor power  $\geq 0,75$  kW).

\*Dimensions of IE3-v2 motor.

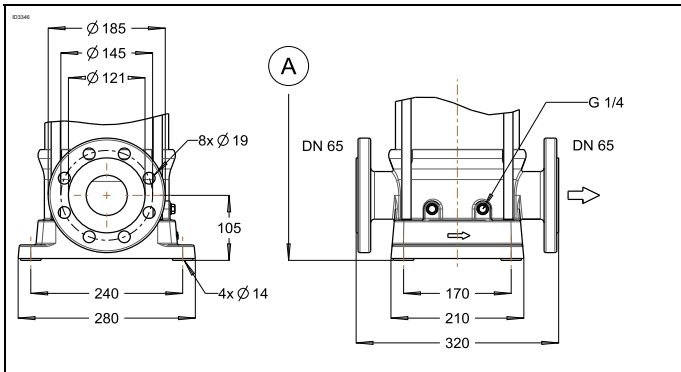

20101130-A

**DPV C F Cast iron flange**  
 Norm: EN 1092-1/1092-2  
 Size: NW65  
 Pressure Class: PN40

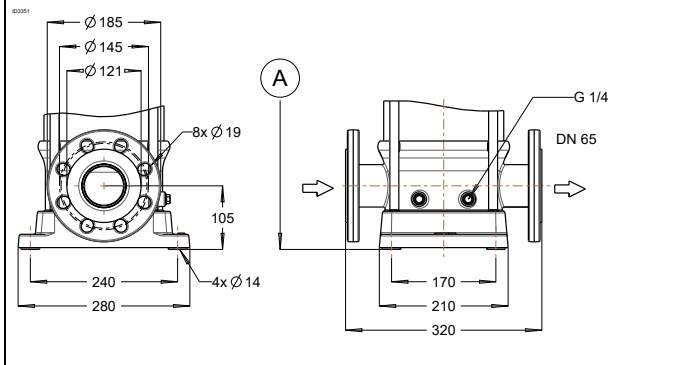

20081105-A

**DPV (S) F Loose plate flange**  
 Cataphoric coated loose plate flange  
 Norm: EN 1092-1/1092-2  
 Size: NW65  
 Pressure Class: PN40  
 Option: Loose plate flange (PN25) in SS 1.4308

## 4.10 DPV(C/S) 25 B - 50Hz - 4 pole - DIN

coupled motor construction type; V18

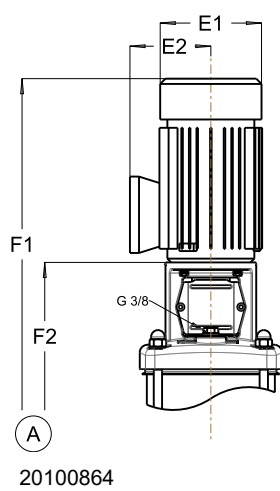

Model	Pressure class	Power [kW]	Motor dimensions <sup>1</sup>			DPV(C/S)F		
			E1 [mm]	E2 [mm]	P [mm]	F1 [mm]	F2 [mm]	Mass [kg]
25/1	PN10	1,1	180	145		693	408	66
25/2		1,1	180	145		758	473	69
25/3		1,1	180	145		823	538	71
25/4		1,1	180	145		888	603	74
25/5		1,1	180	145		953	668	78
25/6		1,5	180	145		1043	733	83
25/7		1,5	180	145		1108	798	85
25/8		2,2	200	155		1186	868	98
25/9		2,2	200	155		1251	933	101
25/10		2,2	200	155		1316	998	103
25/11		2,2	200	155		1381	1063	107
25/12		3	200	155		1490	1128	109

1. All motor dimensions are only valid for Wonder motors with efficiency class IE3.

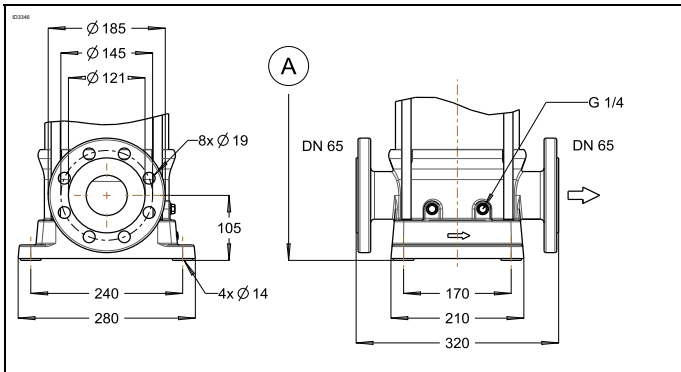

**DPV C F Cast iron flange**  
 Norm: EN 1092-1/1092-2  
 Size: NW65  
 Pressure Class: PN40

20101130-A

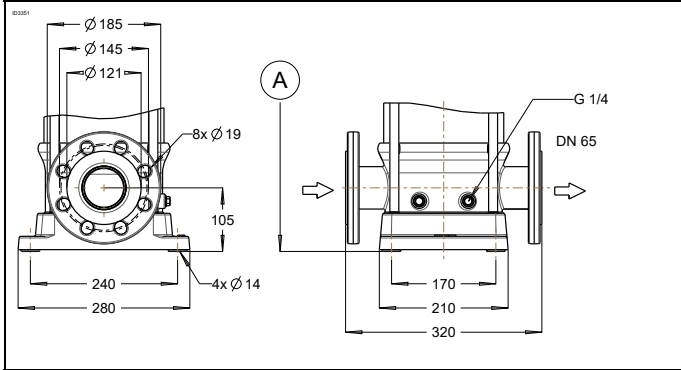

**DPV (S) F Loose plate flange**  
 Cataphoric coated loose plate flange  
 Norm: EN 1092-1/1092-2  
 Size: NW65  
 Pressure Class: PN40  
 Option: Loose plate flange (PN25) in SS 1.4308

20081105-A



## 4.11 DPV(C/S) 40 B - 50Hz - 2 pole - DIN

coupled motor construction type; V18

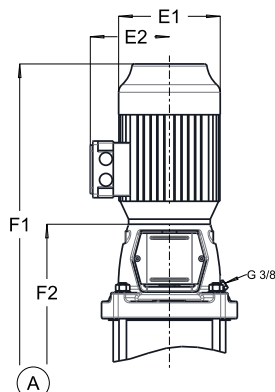

20120682

Model	Pressure class	Power [kW]	Motor dimensions <sup>1</sup>			DPV(C/S)F		
			E1 [mm]	E2 [mm]	P [mm]	F1 [mm]	F2 [mm]	Mass [kg]
40/1-1	PN10	3*	215	157		804	487	92
40/1		4*	248	168		843	487	98

\*Dimensions of IE3-v2 motor.coupled motor

construction type; V1

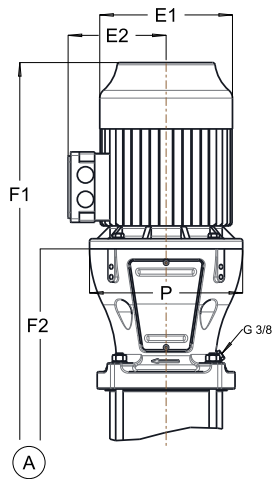

20120681

Model	Pressure class	Power [kW]	Motor dimensions <sup>1</sup>			DPV(C/S)F		
			E1 [mm]	E2 [mm]	P [mm]	F1 [mm]	F2 [mm]	Mass [kg]
40/2-2	PN10	5,5	288	197	300	1087	655	129
40/2		7,5	288	197	300	1087	655	133
40/3-2		11	340	223	350	1296	763	214
40/3		11	340	223	350	1296	763	214
40/4-2		15	340	223	350	1374	841	230
40/4	PN16	15	340	223	350	1374	841	230
40/5-2		18,5	340	223	350	1452	919	261
40/5		18,5	340	223	350	1452	919	261
40/6-2		18,5	340	223	350	1530	997	264
40/6	PN25	22	360	234	350	1645	997	300
40/7-2		22	360	234	350	1723	1075	308
40/7		30	400	340	400	1745	1075	374
40/8-2		30	400	340	400	1823	1153	397
40/8		30	400	340	400	1823	1153	397
40/9-2		30	400	340	400	1901	1231	402
40/9		37	400	340	400	1901	1231	406
40/10-2		37	400	340	400	1979	1309	410
40/10		37	400	340	400	1979	1309	410

1. All motor dimensions are only valid for Cantoni motors with efficiency class IE3. \*Dimensions of IE3-v2 motor.



	<p><b>DPV C F Cast iron flange</b>  Norm: EN 1092-1/1092-2  Size: NW80  Pressure Class: PN16/25/40</p>
	<p><b>DPV C F Cast iron flange</b>  Norm: EN 1092-1/1092-2  Size: NW65  Pressure Class: PN16/25/40</p>
	<p><b>DPV (S) F Loose plate flange</b>  Cataphoric coated loose plate flange  Norm: EN 1092-1/1092-2  Size: NW80  Pressure Class: PN16/25  Option: Loose plate flange cast SS1.4308</p>
	<p><b>DPV (S) F Stainless steel flanges</b>  DPVF: SS 1.4308 / DPVSF: SS 1.4408  Norm: EN 1092-1/1092-2  Size: NW80  Pressure Class: PN40</p>
	<p><b>DPV (S) F Loose plate flange</b>  Cataphoric coated loose plate flange  Norm: EN 1092-1/1092-2  Size: NW80 interchangeable range 45  Pressure Class: PN16/25</p>

## 4.12 DPV(C/S) 40 B - 50Hz - 4 pole - DIN

coupled motor construction type; V18

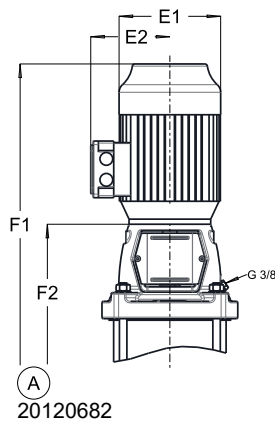

Model	Pressure class	Power [kW]	Motor dimensions <sup>1</sup>			DPV(C/S)F		
			E1 [mm]	E2 [mm]	P [mm]	F1 [mm]	F2 [mm]	Mass [kg]
40/4	PN10	2,2	200	155		1039	721	103
40/5		3	200	155		1161	799	110
40/6		3	200	155		1239	877	113
40/7		4	223	166		1280	955	131
40/8		4	223	166		1358	1033	144
40/9		4	223	166		1436	1111	158

coupled motor construction type; V1

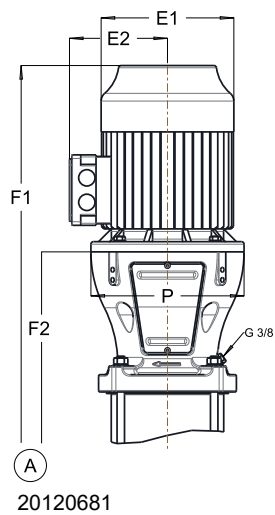

Model	Pressure class	Power [kW]	Motor dimensions <sup>1</sup>			DPV(C/S)F		
			E1 [mm]	E2 [mm]	P [mm]	F1 [mm]	F2 [mm]	Mass [kg]
40/10	PN10	5,5	260	190	300	1629	1279	197

1. All motor dimensions are only valid for Wonder motors with efficiency class IE3 (motor power  $\geq 0,75$ kW).

	<p><b>DPV C F Cast iron flange</b>  Norm: EN 1092-1/1092-2  Size: NW80  Pressure Class: PN16</p> <p style="writing-mode: vertical-rl; transform: rotate(180deg);">20130953</p>
	<p><b>DPV (S) F Loose plate flange</b>  Cataphoric coated loose plate flange  Norm: EN 1092-1/1092-2  Size: NW80  Pressure Class: PN16  Option: Loose plate flange cast SS1.4308</p> <p style="writing-mode: vertical-rl; transform: rotate(180deg);">20130943</p>
	<p><b>DPV (S) F Loose plate flange</b>  Cataphoric coated loose plate flange  Norm: EN 1092-1/1092-2  Size: NW80 interchangeable range 45  Pressure Class: PN16  Option: Loose plate flange cast SS1.4308</p> <p style="writing-mode: vertical-rl; transform: rotate(180deg);">20130943</p>

### 4.13 DPV(C/S) 60 B - 50Hz - 2 pole - DIN

coupled motor construction type; V18

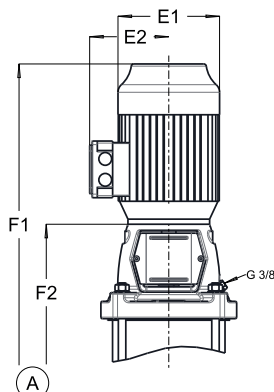

20120682

\*Dimensions of IE3-v2 motor.

Model	Pressure class	Power [kW]	Motor dimensions <sup>1</sup>			DPV(C/S)F		
			E1 [mm]	E2 [mm]	P [mm]	F1 [mm]	F2 [mm]	Mass [kg]
60/1-1	PN10	4*	248	168		843	487	102

coupled motor construction type; V1

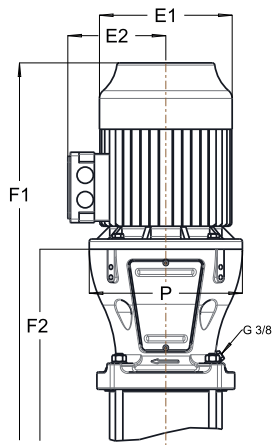

20120681

Model	Pressure class	Power [kW]	Motor dimensions <sup>1</sup>			DPV(C/S)F		
			E1 [mm]	E2 [mm]	P [mm]	F1 [mm]	F2 [mm]	Mass [kg]
60/1	PN10	5,5	288	197	300	1009	577	130
60/2-2		7,5	288	197	300	1087	655	138
60/2		11	340	223	350	1218	685	215
60/3-2		15	340	223	350	1296	763	228
60/3		18,5	340	223	350	1296	763	245
60/4-2	PN16	18,5	340	223	350	1374	841	251
60/4		22	360	234	350	1489	841	287
60/5-2		22	360	234	350	1567	919	300
60/5		30	400	340	400	1569	919	362
60/6-2	PN25	30	400	340	400	1647	997	370
60/6		30	400	340	400	1647	997	376
60/7-2		37	400	340	400	1745	1075	384
60/7		37	400	340	400	1745	1075	384
60/8-2		37	400	340	400	1823	1153	407
60/8		45	450	365	450	1863	1153	484
60/9-2	PN40	45	450	365	450	1941	1231	488

1. All dimensions are only valid for Cantoni motors with efficiency class IE3. Motor power  $\geq 30$  kW: All dimensions are only valid for Wonder motors with efficiency class IE3. \*Dimensions of IE3-v2 motor.

	<p><b>DPV C F Cast iron flange</b>  Norm: EN 1092-1/1092-2  Size: NW100  Pressure Class:PN16</p>
	<p><b>DPV C F Cast iron flange</b>  Norm: EN 1092-1/1092-2  Size: NW100  Pressure Class:PN25/40</p>
	<p><b>DPV (S) F Loose plate flange</b>  Cataphoric coated loose plate flange  Norm: EN 1092-1/1092-2  Size: NW100  Pressure Class: PN16  Option: Loose plate flange cast SS1.4308</p>
	<p><b>DPV (S) F Loose plate flange</b>  Cataphoric coated loose plate flange  Norm: EN 1092-1/1092-2  Size: NW100  Pressure Class: PN25/40  Option: Loose plate flange cast SS1.4308</p>
	<p><b>DPV (S) F Stainless steel flanges</b>  DPVF: SS 1.4308 / DPVSF: SS 1.4408  Norm: EN 1092-1/1092-2  Size: NW100  Pressure Class: PN40</p>



#### 4.14 DPV(C/S) 60 B - 50Hz - 4 pole - DIN

coupled motor construction type; V18

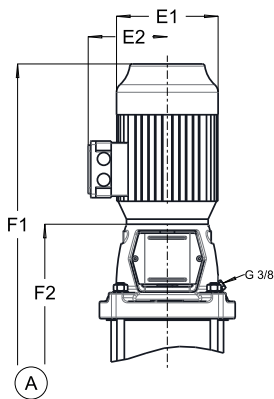

20120682

Model	Pressure class	Power [kW]	Motor dimensions <sup>1</sup>			DPV(C/S)F		
			E1 [mm]	E2 [mm]	P [mm]	F1 [mm]	F2 [mm]	Mass [kg]
60/3	PN10	2,2	200	155		961	643	103
60/4		3	200	155		1083	721	108
60/5		4	223	166		1124	799	123
60/6		4	223	166		1202	877	127

coupled motor construction type; V1

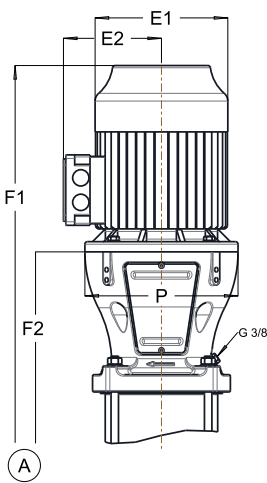

20120681

Model	Pressure class	Power [kW]	Motor dimensions <sup>1</sup>			DPV(C/S)F		
			E1 [mm]	E2 [mm]	P [mm]	F1 [mm]	F2 [mm]	Mass [kg]
60/7	PN10	5,5	260	190	300	1395	1045	179
60/8		5,5	260	190	300	1473	1123	193
60/9		7,5	260	190	300	1588	1201	209
60/10		7,5	260	190	300	1666	1279	213

1. All motor dimensions are only valid for Wonder motors with efficiency class IE3 (motor power  $\geq 0,75$ kW).

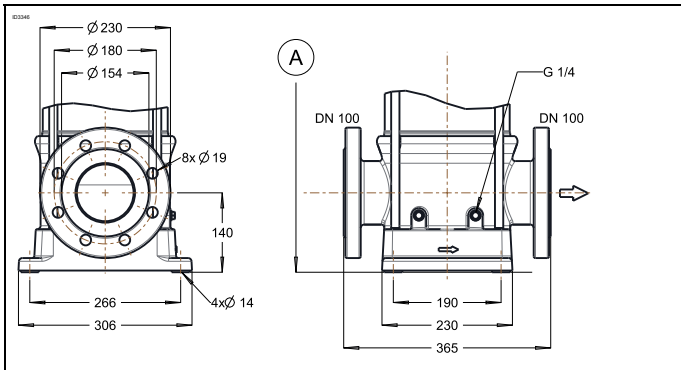

**DPV C F Cast iron flange**  
 Norm: EN 1092-1/1092-2  
 Size: NW100  
 Pressure Class: PN16

20120677

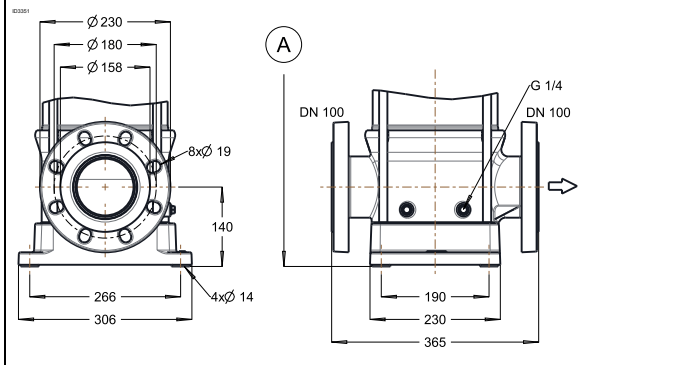

**DPV (S) F Loose plate flange**  
 Cataphoric coated loose plate flange  
 Norm: EN 1092-1/1092-2  
 Size: NW100  
 Pressure Class: PN16  
 Option: Loose plate flange cast SS1.4308

20101155



## 4.15 DPV(C/S) 85 B - 50Hz - 2 and 4 pole - DIN

coupled motor construction type; V1

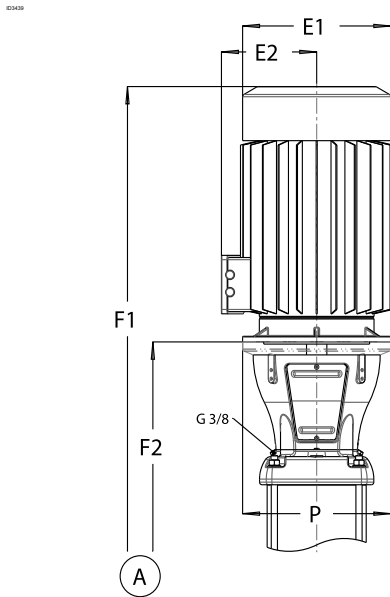

20091237

Model	Pressure class	Power [kW]	Motor dimensions <sup>1</sup>			DPV(C/S)F		
			E1 [mm]	E2 [mm]	P [mm]	F1 [mm]	F2 [mm]	Mass [kg]
85/1-1	PN10	5,5	288	197	300	1073	641	143
85/1		7,5	288	197	300	1073	641	147
85/2-2		11	340	223	350	1313	780	234
85/2-1		15	340	223	350	1313	780	248
85/2		15	340	223	350	1313	780	248
85/3-2		18,5	340	223	350	1422	889	276
85/3-1	PN16	22	360	234	350	1537	889	312
85/3		22	360	234	350	1537	889	312
85/4-2		30	400	340	400	1668	998	406
85/4-1	PN16	30	400	340	400	1668	998	406
85/4		30	400	340	400	1668	998	406
85/5-2		37	400	340	400	1777	1107	438
85/5-1		37	400	340	400	1777	1107	438
85/5		37	400	340	400	1777	1107	438
85/6-2	PN25/40	45	450	365	450	1926	1216	574
85/6-1		45	450	365	450	1926	1216	575
85/6		45	450	365	450	1926	1216	575

1. All dimensions are only valid for Cantoni motors with efficiency class IE3. Motor power  $\geq 30$  kW: All dimensions are only valid for Wonder motors with efficiency class IE3.

coupled motor construction type; V1, 4 pole

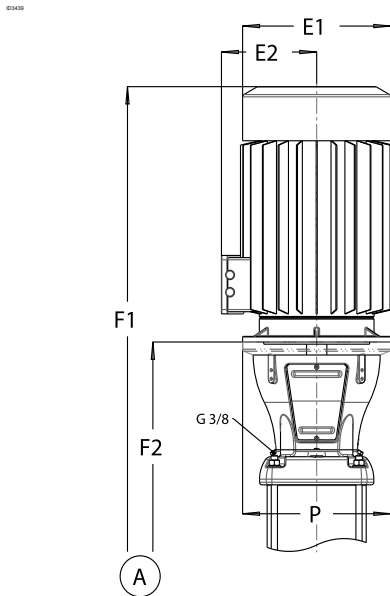

20091237

Model	Pressure class	Power [kW]	Motor dimensions <sup>1</sup>			DPV(C/S)F		
			E1 [mm]	E2 [mm]	P [mm]	F1 [mm]	F2 [mm]	Mass [kg]
85/5-2	PN10	5,5	260	190	300	1427	1077	217
85/5-1		5,5	260	190	300	1427	1077	217
85/5		5,5	260	190	300	1427	1077	217
85/6-2		5,5	260	190	300	1536	1186	227
85/6-1		5,5	260	190	300	1536	1186	227
85/6		5,5	260	190	300	1536	1186	227

1. All motor dimensions are only valid for Wonder motors with efficiency class IE3 (motor power  $\geq 0,75$  kW).



	<p><b>DPV C F Cast iron flange</b>  Norm: EN 1092-1/1092-2  Size: NW100  Pressure Class:PN16</p> <p style="text-align: right;">20090642</p>
	<p><b>DPV C F Cast iron flange</b>  Norm: EN 1092-1/1092-2  Size: NW100  Pressure Class:PN25/40</p> <p style="text-align: right;">20090643</p>
	<p><b>DPV (S) F Loose plate flange</b>  Cataphoric coated loose plate flange  Norm: EN 1092-1/1092-2  Size: NW100  Pressure Class: PN16  Option: Loose plate flange and baseplate in cast SS1.4308</p> <p style="text-align: right;">20090642</p>
	<p><b>DPV (S) F Loose plate flange</b>  Cataphoric coated loose plate flange  Norm: EN 1092-1/1092-2  Size: NW100  Pressure Class: PN25/40  Option: Loose plate flange and baseplate in cast SS1.4308</p> <p style="text-align: right;">20090643</p>

## 4.16 DPV(C/S) 125 B - 50Hz - 2 pole - DIN

coupled motor construction type; V1

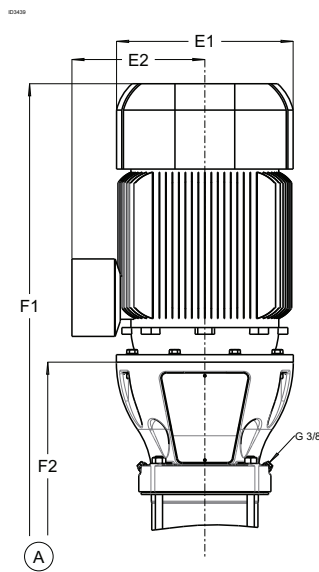

20150648

Model	Pressure class	Power [kW]	Motor dimensions <sup>1</sup>			DPV(C/S)F		DPVCF	DPV(S)F
			E1 [mm]	E2 [mm]	P [mm]	F1 [mm]	F2 [mm]	Mass [kg]	Mass [kg]
125/1	PN10	15	340	223	350	1277	739	264	284
125/2-2		18,5	340	223	350	1407	869	291	311
125/2-1		22	360	234	350	1519	869	329	349
125/2		30	400	340	400	1539	869	426	445
125/3-2		30	400	340	400	1669	999	442	462
125/3-1	PN16	37	400	340	400	1669	999	462	482
125/3		37	400	340	400	1669	999	462	482
125/4-2		45	450	365	450	1829	1119	535	555

1. All dimensions are only valid for Cantoni motors with efficiency class IE3. Motor power  $\geq 30$  kW: All dimensions are only valid for Wonder motors with efficiency class IE3.

	<p><b>DPV C F with cast iron flange</b>  Norm: EN 1092-1/1092-2  Size: NW125  Pressure Class: PN16</p> <p style="writing-mode: vertical-rl; transform: rotate(180deg);">20150646</p>
	<p><b>DPV C F with cast iron flange</b>  Norm: EN 1092-1/1092-2  Size: NW125  Pressure Class: PN25</p> <p style="writing-mode: vertical-rl; transform: rotate(180deg);">20150647</p>
	<p><b>DPV (S) F with loose plate flange</b>  Cataphoric coated loose plate flange  Norm: EN 1092-1/1092-2  Size: NW125  Pressure Class: PN16  Option: Loose plate flange in cast SS1.4308</p> <p style="writing-mode: vertical-rl; transform: rotate(180deg);">20150646</p>
	<p><b>DPV (S) F with stainless steel flange</b>  Norm: EN 1092-1/1092-2  Size: NW125  Pressure Class: PN25</p> <p style="writing-mode: vertical-rl; transform: rotate(180deg);">20150647</p>

# 5 Seals

## 5.1 Mechanical seal option specifications

Seal code

Shaft seal Type	Material mechanical seal	Seal code	Material shaft seal	Material pump elastomer	Temperature range shaft seal [°C]	Max. pressure [bar]	Fixed	Easy Access	Cartridge
MG-G60	B Q1 E GG	11	Ca / SiC / EPDM	EPDM	-20 - 100	10	●	●	●
MG-G60	B Q1 V GG	12	Ca / SiC / FPM	FPM	-20 - 120	10	●	●	●
RMG-G606	Q1 B E GG	13	SiC / Ca / EPDM	EPDM WRAS / ACS	-20 - 100	25	●	●	●
RMG-G606	Q1 B V GG	14	SiC / Ca / FPM	FPM	-20 - 120	25	●	●	●
RMG-G606	U3 U3 X4 GG	15	TuC / TuC / HNBR	HNBR	-20 - 120 (140)	25 (16)	●	●	●
RMG-G606	U3 U3 V GG	16	TuC / TuC / FPM	FPM	-20 - 120 (140)	25 (16)	●	●	●
RMG-G606	U3 B E GG	18	TuC / Ca / EPDM	EPDM 559236	-20 - 120 (140)	25 (16)	●	●	●
H7N	Q1 A E GG	20	SiC / Ca / EPDM	EPDM 559236	-20 - 120 (140)	40 (25)			●
H7N	Q1 A V GG	21	SiC / Ca / FPM	FPM	-20 - 120 (140)	40 (25)			●
H7N	Q1 A X4 GG	22	SiC / Ca / HNBR	HNBR	-20 - 120 (140)	40 (25)			●
RMG-G606	Q1 B E GG	23	SiC / Ca / EPDM	EPDM	-20 - 100	25	●	●	●
MG-G606	Q1 Q1 V GG	24	SiC / SiC / FPM	FPM	-20 - 120	10	●	●	●
MG-G606	Q1 Q1 X4 GG	28	SiC / SiC / HNBR	HNBR	-20 - 120	10	●	●	●
MG-G606	Q1 Q1 E GG	29	SiC / SiC / EPDM	EPDM	-20 - 100	10	●	●	●
MG-G60	Q1 Q1 V GG	30	SiC / SiC / FPM	FPM / PTFE	-20 - 120	10		●	
RMG-G606	Q1 B E GG	33	SiC / Ca / EPDM	EPDM NSF	-20 - 100	25	●	●	●
RMG-G6	eCa eSiC E GG	35	eCa / eSiC / EPDM	EPDM WRAS / ACS	-20 - 120	25			●
MG-G6	eCa eSiC V GG	36	eCa / eSiC / FPM	FPM	-20 - 120	25			●
RMG-G606	U3 A V GG	37	TuC / Ca / FPM	FPM	-20 - 120 (140)	25 (16)			●
4MC	Q1 Q1 E GG	40	SiC / SiC / EPDM	EPDM 559236	-20 - 120 (140)	40 (25)			●
4MC	Q1 B E GG	41	SiC / Ca / EPDM	EPDM 559236	-20 - 120 (140)	40 (25)			●
4MC	Q1 Q1 V GG	42	SiC / SiC / FPM	FPM	-20 - 120 (140)	40 (25)			●
4MC	Q1 B V GG	43	SiC / Ca / FPM	FPM	-20 - 120 (140)	40 (25)			●



Seal dimensions according to EN24960

# 6 Motors and motor options

## 6.1 General

The standard DP motors are produced in conformity with the latest technical design, and comply with the international standards and EU directives regarding safety measures.

*The motors can be specified as:*

- Efficiency class for motors: standard IE3  $\geq 0,75$  kW
- T.E.F.C. (totally enclosed fan cooled) Squirrel cage.
- Synchron reluctance motor Synchron reluctance motor. (IE4 -IE5).
- AC induction motor.
- Protection IP55.
- Insulation class F.
- Temperature rise class B.
- Duty class S1, maximum starts see table 39.
- Noise levels conform IEC 60034-9.
- $> 2,2$  kW standard 3 x PTC.

The motors are available in three different construction types. Mounting in acc. with IEC60034-7 and dimensions in acc. with IEC 60072-1.

## 6.2 Options

- Standard motors as per above, but in 4 pole version (low speed) (for sizes 10, 15, 25, 40, 60 and 85).
- Standard motors as per above, in single phase (1x230V) upto and including 2.2 kW
- Provided with 10 pole industrial connector "Harting stecker" HAN 10, mounted in stead of the motor connection box,  $\leq 7,5$  kW.
- Provided with Rain cover on top of the fan hood.
- For motors  $< 3$  kW provided with 3 x PTC and/or anti condensation heater (1x230V).
- Motors from other manufacturers like Siemens and VEM
- Explosion proof, class Ex eb IIC T3.
- Explosion proof, class Ex db eb IIC T4.
- Marine approved variant according to Bureau Veritas

02042

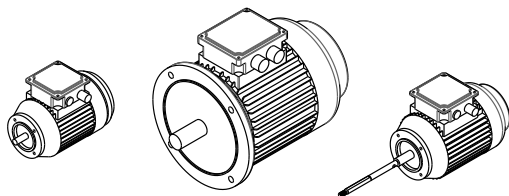

V18 flange

V1 flange

close coupled (VM)

20091254

## 6.3 Standard motor data

Motor data 1 and 3 phase, 2p 50Hz

Article number	Rated power output [kW]	Frame size	Motor efficiency class	Rated Voltage [V]	Rated current [A]	Starting current Ia/In	Cos Phi	Tolerance rated voltage	Rated speed [rpm]	Motor efficiency 50%	Motor efficiency 75%	Motor efficiency 100%	Sound pressure [dB(A)]	Cable gland	Max. starts per hour
3700000003	0,37	71-1	-	1x230	2,6	3,7	0,92	10%	2750	-	-	67	58	1xM18x1,5	20
3700000005	0,55	71-2	-	1x230	3,69	3,9	0,92	10%	2760	-	-	70	56	1xM18x1,5	20
3700000007	0,75	80-1	-	1x230	5,0	3,9	0,92	10%	2780	-	-	72	56	1xM20x1,5	20
3700000011	1,1	80-2	-	1x230	6,68	4,3	0,95	10%	2790	-	-	75	58	1xM20x1,5	20
3700000015	1,5	90S	-	1x230	8,99	4,8	0,95	10%	2800	-	-	76	58	1xM20x1,5	20
3700000022	2,2	90L	-	1x230	13,04	4,8	0,95	10%	2800	-	-	77	58	1xM20x1,5	20
3727011003	0,37	71B	IE2	230/400	1,6/0,95	4,5	0,76	10%	2865	-	-	76	60	1xM20x1,5	50
3727011005	0,55	71C	IE2	230/400	2,1/1,2	5,3	0,8	10%	2880	-	-	82	60	1xM20x1,5	50
3710051007	0,75	80A	IE3	230/400	3,1/1,8	6,6	0,76	10%	2880	75,5	79,5	80,7	55	1xM20x1,5	50
3710051011	1,1	80B	IE3	230/400	4,0/2,3	6,4	0,81	10%	2880	83,9	85,1	84,0	55	1xM20x1,5	50
3716051015	1,5*	90S	IE3	230/400	5,3/3,0	7,3	0,85	10%	2925	82,7	84,5	84,2	55	1xM20x1,5	50
3716051022	2,2*	90L	IE3	230/400	7,5/4,3	8,0	0,86	10%	2910	85,4	86,5	85,9	55	1xM20x1,5	30
3710151030	3	100L	IE3	230/400	10,2/5,8	9,3	0,85	10%	2920	86,2	87,7	87,1	57	2xM20x1,5	30
3716152030	3*	100L	IE3	400/690	5,8/3,3	9,3	0,85	10%	2920	86,9	87,7	87,1	57	2xM20x1,5	30
3710151040	4	112M	IE3	230/400	12,8/7,4	9,5	0,89	10%	2930	88,1	88,8	88,1	58	2xM20x1,5	30
3716752040	4*	112M	IE3	400/690	7,4/4,3	8,4	0,89	10%	2930	88,7	89,0	88,1	58	2xM20x1,5	30
3716151055	5,5	132S	IE3	230/400	17,3/10,0	8,8	0,89	10%	2940	87,7	89,2	89,2	63	2xM25x1,5	20
3716152055	5,5	132S	IE3	400/690	10,0/5,8	8,8	0,89	10%	2940	87,7	89,2	89,2	63	2xM25x1,5	20
3716151075	7,5	132S	IE3	230/400	23,0/13,3	9,2	0,89	10%	2940	89,0	90,3	90,1	63	2xM25x1,5	20
3716152075	7,5	132S	IE3	400/690	13,2/7,7	9,2	0,89	10%	2940	89,0	90,3	90,1	63	2xM25x1,5	20
3710151110	11	160M	IE3	230/400	33,4/19,3	7,3	0,9	10%	2945	89,7	91,0	91,2	69	2xM32x1,5	15
3710152110	11	160M	IE3	400/690	19,3/11,2	7,3	0,9	10%	2945	89,7	91,0	91,2	69	2xM32x1,5	15
3710151150	15	160M	IE3	230/400	45,4/26,2	7,4	0,9	10%	2945	89,8	91,9	91,9	69	2xM32x1,5	15
3710152150	15	160M	IE3	400/690	26,2/15,2	7,4	0,9	10%	2945	89,8	91,9	91,9	69	2xM32x1,5	15
3710151185	18,5	160L	IE3	230/400	55,6/32,1	7,7	0,9	10%	2940	92,2	92,8	92,4	69	2xM32x1,5	15
3710152185	18,5	160L	IE3	400/690	32,1/18,6	7,7	0,9	10%	2940	92,2	92,8	92,4	69	2xM32x1,5	15
3710151220	22	180M	IE3	230/400	66,0/38,1	9,2	0,9	10%	2955	92,1	92,9	92,7	74	2xM32x1,5	12
3710152220	22	180M	IE3	400/690	38,1/22,1	9,2	0,9	10%	2955	92,1	92,9	92,7	74	2xM32x1,5	12
3700151300	30	200L	IE3	230/400	89,7/51,6	8,5	0,9	10%	2965	92,3	93,2	93,3	73	2xM50x1,5	12
3700152300	30	200L	IE3	400/690	51,6/29,9	8,5	0,9	10%	2965	92,3	93,2	93,3	73	2xM50x1,5	15
3700151370	37	200L	IE3	230/400	110/63,3	8,5	0,9	10%	2965	92,8	93,8	93,7	73	2xM50x1,5	15
3700152370	37	200L	IE3	400/690	63,3/36,7	8,5	0,9	10%	2965	92,8	93,8	93,7	73	2xM50x1,5	15
3700151450	45	225M	IE3	230/400	134/76,8	8,5	0,9	10%	2970	93,2	94,2	94,0	75	2xM50x1,5	15
3700152450	45	225M	IE3	400/690	76,8/44,5	8,5	0,9	10%	2970	93,2	94,2	94,0	75	2xM50x1,5	15

\* Dimensions of IE3-v2 motor.

Motor data 3 phase, 4p 50Hz

Article number	Rated power output [kW]	Frame size	Motor efficiency class	Rated Voltage [V]	Rated current [A]	Starting current Ia/In	Cos Phi	Tolerance rated voltage	Rated speed [rpm]	Motor efficiency 50%	Motor efficiency 75%	Motor efficiency 100%	Sound pressure [dB(A)]	Cable gland	Starts per hour
3728031005	0,55	80M1	IE2	230/400	2,34/1,34	5,3	0,73	10%	1425	-	-	80,7	57	1xM20x1,5	20
3700061007	0,75	80	IE3	230/400	3,13/1,8	6,5	0,73	10%	1425	80,0	82,6	82,5	57	2xM20x1,5	25
3700061011	1,1	90	IE3	230/400	4,21/2,42	6,5	0,78	10%	1440	82,9	84,4	84,4	58	2xM25x1,5	25
3700061015	1,5	90	IE3	230/400	5,59/3,21	7,0	0,79	10%	1440	83,8	85,5	85,3	58	2xM25x1,5	25
3700061022	2,2	100	IE3	230/400	7,86/4,52	7,5	0,81	10%	1445	86,1	87,1	86,7	59	2xM25x1,5	20
3700161030	3	100	IE3	230/400	10,6/6,1	7,5	0,81	10%	1445	87,1	88,2	87,7	59	2xM25x1,5	20
3700162030	3	100	IE3	400/690	6,1/3,53	7,5	0,81	10%	1445	87,1	88,2	87,7	59	2xM25x1,5	20
3700161040	4	112	IE3	230/400	14,0/8,05	8,5	0,81	10%	1450	88,1	89,3	88,5	60	2xM25x1,5	20
3700162040	4	112	IE3	400/690	8,05/4,66	8,5	0,81	10%	1450	88,1	89,3	88,6	60	2xM25x1,5	20
3700161055	5,5	132	IE3	230/400	19,0/10,9	8,5	0,81	10%	1460	88,3	89,7	89,9	60	2xM32x1,5	20
3700162055	5,5	132	IE3	400/690	10,9/6,34	8,5	0,81	10%	1460	88,3	89,7	89,6	60	2xM32x1,5	20
3700161075	7,5	132	IE3	230/400	25,4/14,6	8,5	0,82	10%	1460	89,3	90,5	90,4	60	2xM32x1,5	20
3700162075	7,5	132	IE3	400/690	14,6/8,47	8,5	0,82	10%	1460	89,3	90,5	90,4	60	2xM32x1,5	20



# 7 Accessories

## 7.1 Thrust bearing housing (optional)

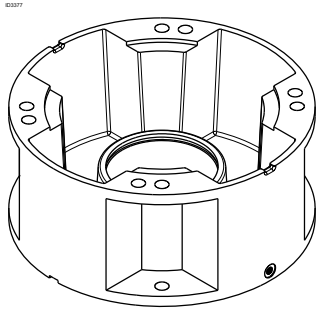

*Thrust bearing housing*

20070627-E

The standard DP Pumps motors are specially designed to drive the pump. When a standard motor has to be installed (or a special motor to fulfil the applications requirement, like explosion proof, high efficiency) a special bearing housing must be installed to relieve the motor of the axial force created by the pump.



This option is not applicable for pump model DPVM.



Only a motor with a standard key can be installed with a thrust bearing housing.



There is no need to change the motor stool of the pump. The bearing flange can be mounted on the standard motor stool of the pump.



# 8 Materials

## 8.1 Parts overview

### 8.1.1 Part list

Part. no.	part description	material code	Wetted part	VC	V	VS
10-6	Pump shroud	1.4301	X	●	●	
		1.4404	X			●
45-4	Spacer DPV(C/S) 85 B	EPDM	X	●	●	○
		FPM	X	○	○	●
		HNBR	X	○	○	○
68.3.02	Cover plate for casing bearing	1.4404	X	●	●	●
101	Pump casing DPV 2-15 (B)	JS1030	X	●		
	Pump casing DPV 25-125 (B)	JL1040	X	●		
		1.4308	X		●	
		1.4408	X			●
	(Loose plate) flange	JL1040			●	●
		1.4308		○	○	
108	Stage Casing DPV 2-60 B, 15C	1.4301	X	●	●	
		1.4404	X			●
108	Stage Casing DPV 85 B - 125	1.4308	X	●	●	
		1.4408	X			●
131	Inlet ring DPV 2-10 B	1.4308	X	●	●	
		1.4408	X			●
160	Cover DPV 2-60, 15 C	1.4301	X		●	
		1.4404	X			●
160	Cover DPV 85 B	1.4308	X	●	●	
		1.4408	X			●
171	Diffuser DPV 25 B	1.4301	X	●	●	
		1.4404	X			●
210	Shaft	1.4057	X	●	●	
		1.4460	X			●
230	Impeller DPV 2-60 B, 15 C	1.4301	X	●	●	
		1.4404	X			●
230	Impeller DPV 85 B	1.4308	X	●	●	
		1.4408	X			●
230	Impeller DPV 125	1.4308 / 1.4301	X	●	●	
		1.4408 / 1.4404	X			●
341	Motor stool 40 - 60 - 125	J1030		●	●	●
341	Motor stool 2 - 25, 85	JL1040		●	●	●
412	Pump sealing elastomers	EPDM	X	●	●	○
		EPDM WRAS/ACS	X	○	○	○
		FPM	X	○	○	●
		EPDM 559236	X	○	○	○



Part. no.	part description	material code	Wetted part	VC	V	VS
		HNBR	X	○	○	○
433	Shaft seal LP (P at Q=0 < 9.2bar)	B Q 1 E GG LP	X	●	●	○
		Q1 B E GG HP <sup>1</sup>	X	●	●	○
	Shaft seal LP (P at Q=0 < 9.2bar)	B Q1 V GG LP	X	○	○	●
		Q1 B V GG HP <sup>1</sup>	X	○	○	●
471	Seal cover	1.4308	X	●	●	○
		1.4408	X	○	○	●
502.02	Casing bearing	PPS 450CA30	X	●	●	●
503	Impeller wear ring DPV 85 B	1.4404	X	●	●	●
511	Center ring DPV 25B	1.4301		●	●	●
525	Spacer sleeve	1.4301	X	●	●	
		1.4404	X			●
529	Bearing sleeve	Tungsten Carbide	X	●	●	●
Part of 108	Bearing	Aluminium Oxide	X	●	●	●
532.01	Extension sleeve	1.4404	X	●	●	●
722	Taper piece	JL1040		●	●	●
723	Counter flange	JL1040	X		●	
		1.4308	X		○	
		1.4408	X			○
862	Coupling from 5.5 kW	JS1030		●	●	●
	Coupling up to 4 kW	Aluminium		●	●	●
890	Base plate	JS1030		●	●	●
	Base plate	1.4308			○	○
	Base plate (for F connection)	JL1040			●	●
901.07	Hexagon head bolt	1.4404	X	●	●	●
903.01	Screwed plug (vent)	1.4301 (A2)	X	●	●	
		1.4404 (A4)	X			●
903.02	Screwed plug (drain)	1.4301 (A2)	X	●	●	
		1.4404 (A4)	X			●
905	Tie bolt	1.4057		●	●	●
914.06	Hexagon socked head cap screw	1.4404	X	●	●	●
920.01	Lock nut	1.4301	X	●	●	
		1.4404	X			●
930	Safety device Nord-lock	1.4404	X	●	●	●
932	Circlip	1.4571	X	●	●	●
950	Wave spring DPV(C/S) 2-15 B/C	1.4401	X	●	●	●

1. HP: high pressure version > 10 bar (P at Q=0 > 9.2 bar)

● Standard ○ Option

### 8.1.2 Materials conversion

Material	Description	Code and material nr.	Standard	ASTM / AISI <sup>1</sup>
JL 1040	Cast iron	GJL-250	EN 1561	A48:40B
JS1030	Cast iron	GJS-400	EN 1563	
1.4057	Chromium-nickel steel	X17CrNi16-2--QT800	EN 10088-3	A276:431
1.4300	Chromium-nickel steel	X12CrNi 18-8	EN 10088	A276:302
1.4301	Chromium-nickel steel	X5CrNi 18-10	EN 10088	A276:304
1.4305	Chromium-nickel steel	X8CrNiS 18-9	EN 10088	A276:303
1.4308	Chromium-nickel cast steel	GX5CrNi 19-10	EN 10283	A743:CF8
1.4401	Chromium-nickel-molybdenum steel	X5CrNiMo 17-12-2	EN 10088	A276:316
1.4404	Chromium-nickel-molybdenum steel	X2CrNiMo 17-12-2	EN 10088	A276:316L
1.4408	Chromium-nickel-molybdenum cast steel	GX5CrNiMo 19-11-2	EN 10213	A743CF8M
1.4460	Chromium-nickel-molybdenum steel	X3CrNiMoN 27 5 2	EN 10088	A276: 329
1.4571	Chromium-nickel-molybdenum steel	X6CrNiMoTi 17-12-2	EN 10088	A276:316Ti

1. Note: The indication of the material designations to ASTM / AISI is not binding

8.1.3 Sectional drawing DPVCF 2/4/6 B

2014

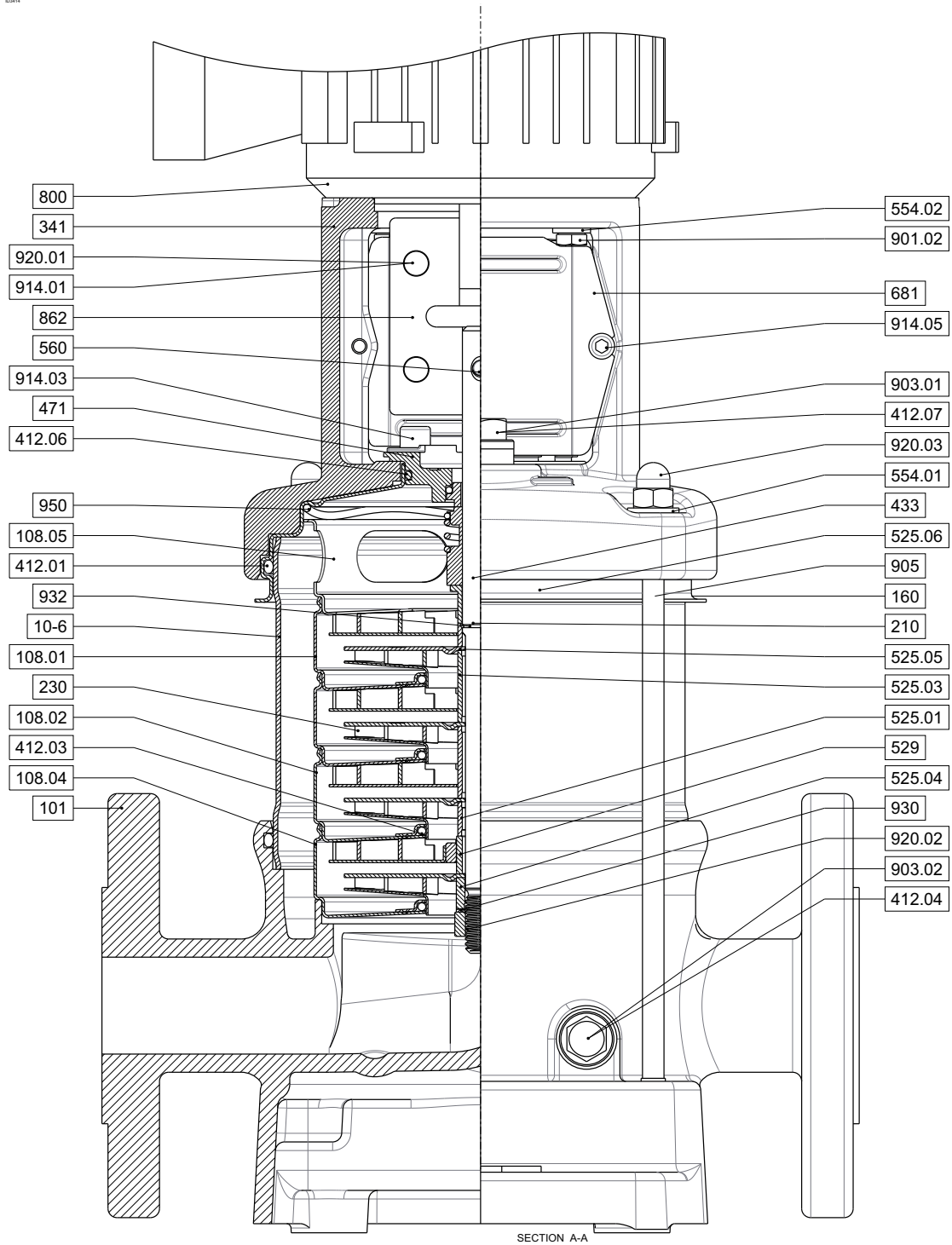

8.1.4 Sectional drawing DPV(S) 2/4/6 B

85413

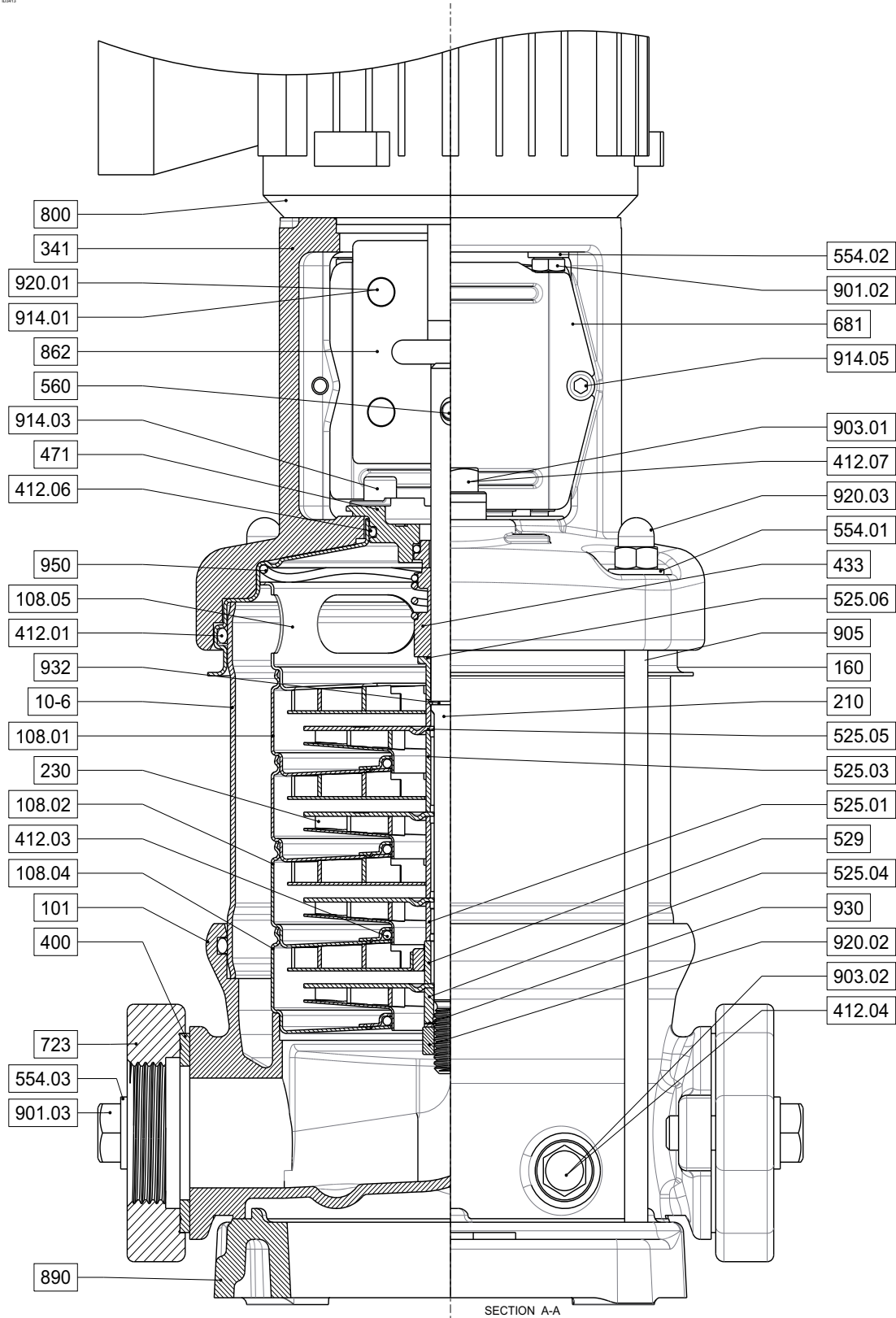

Sectional drawing DPV(S) 2/4/6 B

20080766-H



8.1.5 Sectional drawing DPVCF 10 B

2014

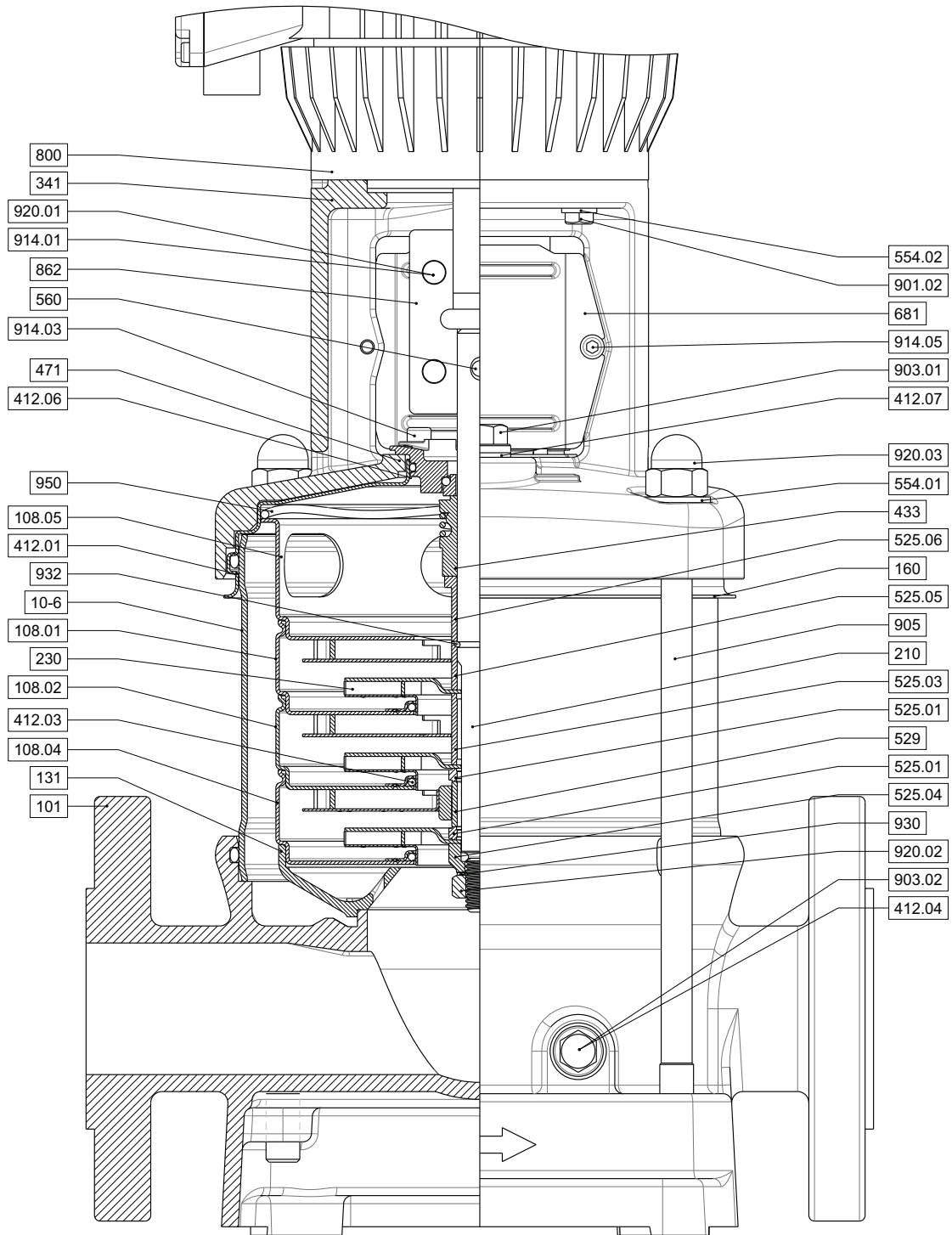

Sectional drawing DPVCF 10 B

8.1.6 Sectional drawing DPV(S) 10 B

20080645

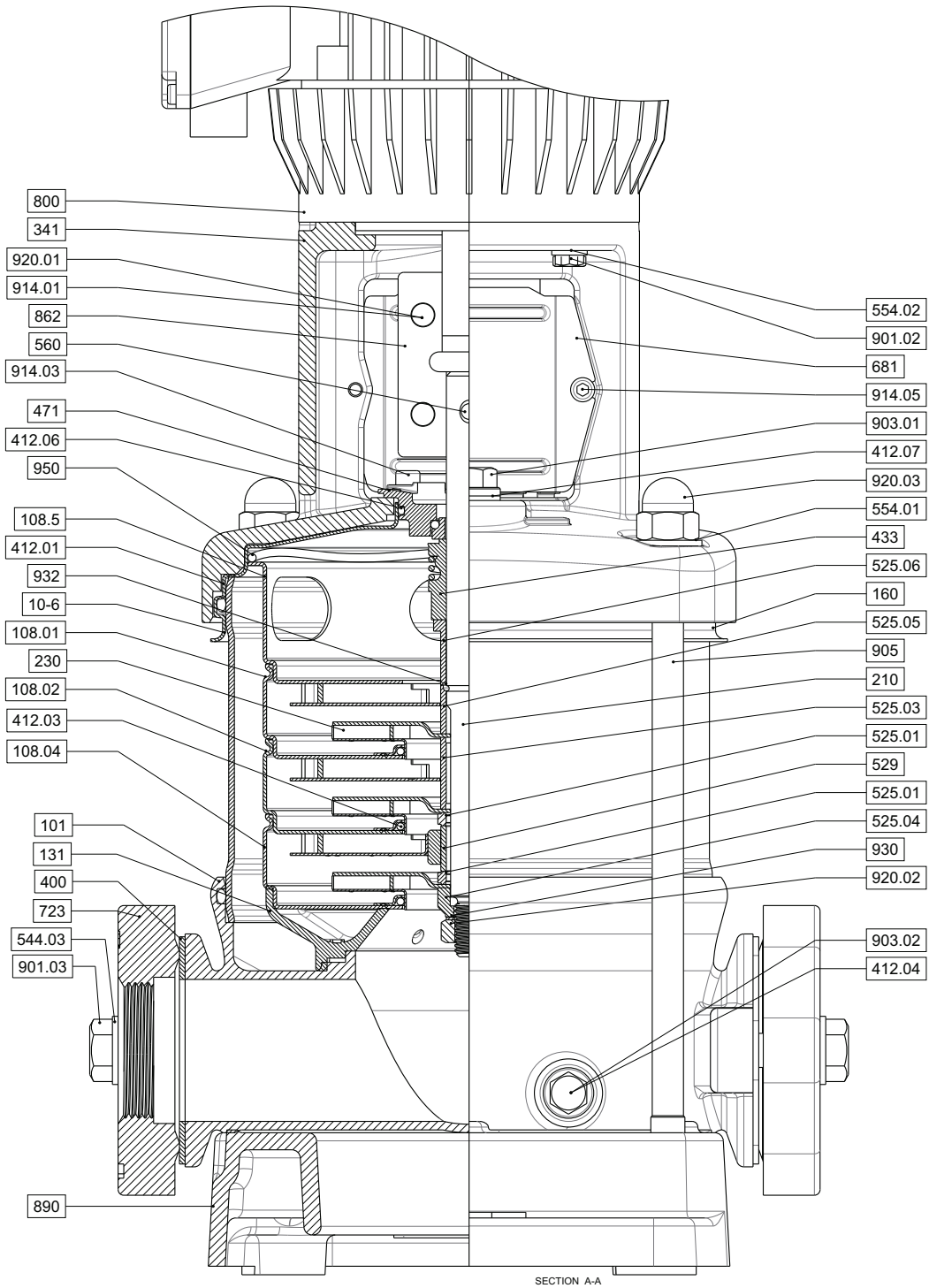

Sectional drawing DPV(S) 10 B



8.1.7 Sectional drawing DPV(S) 15 C

25413

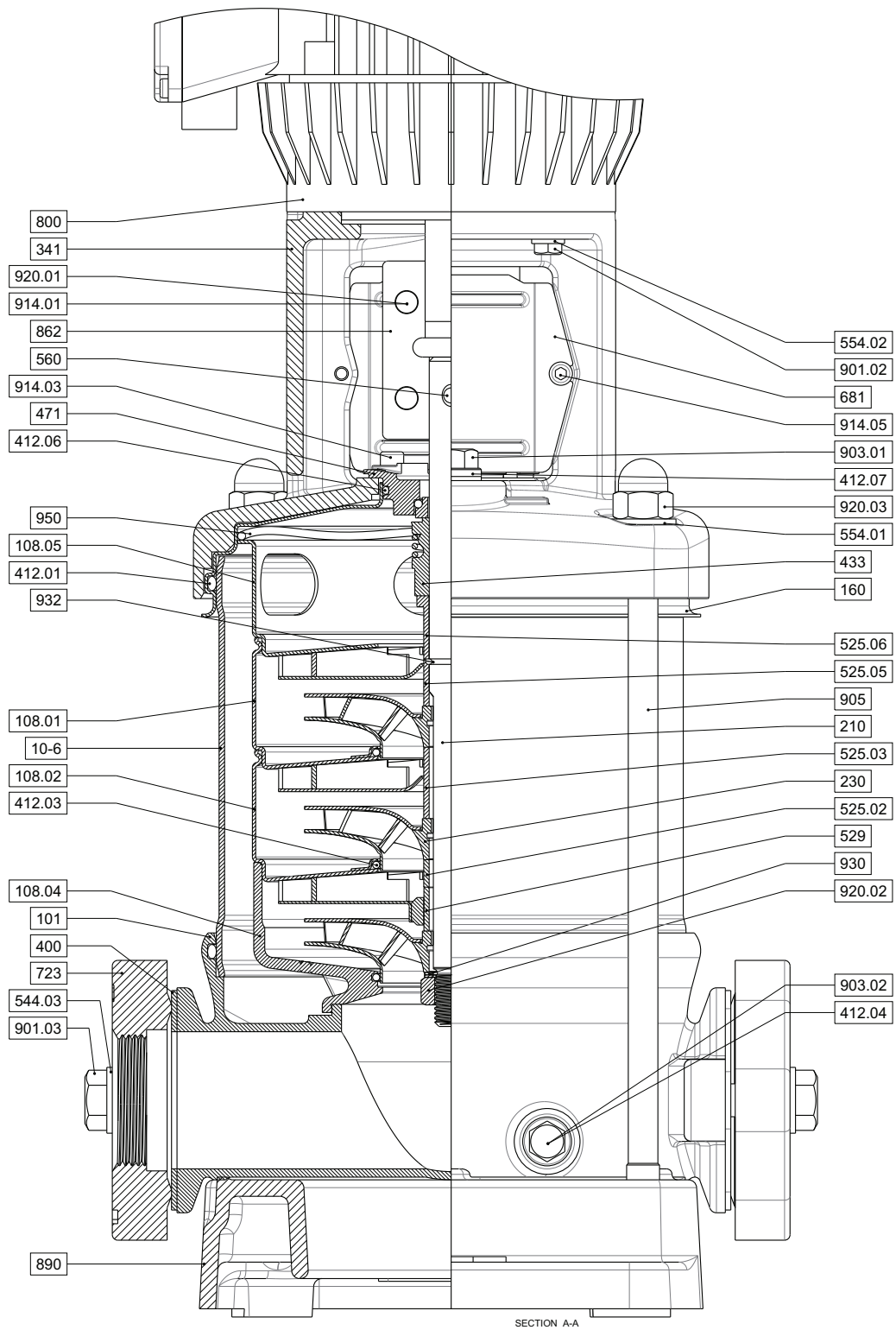

Sectional drawing DPV(S) 15 C



8.1.8 Sectional drawing DPV(S)F 25 B

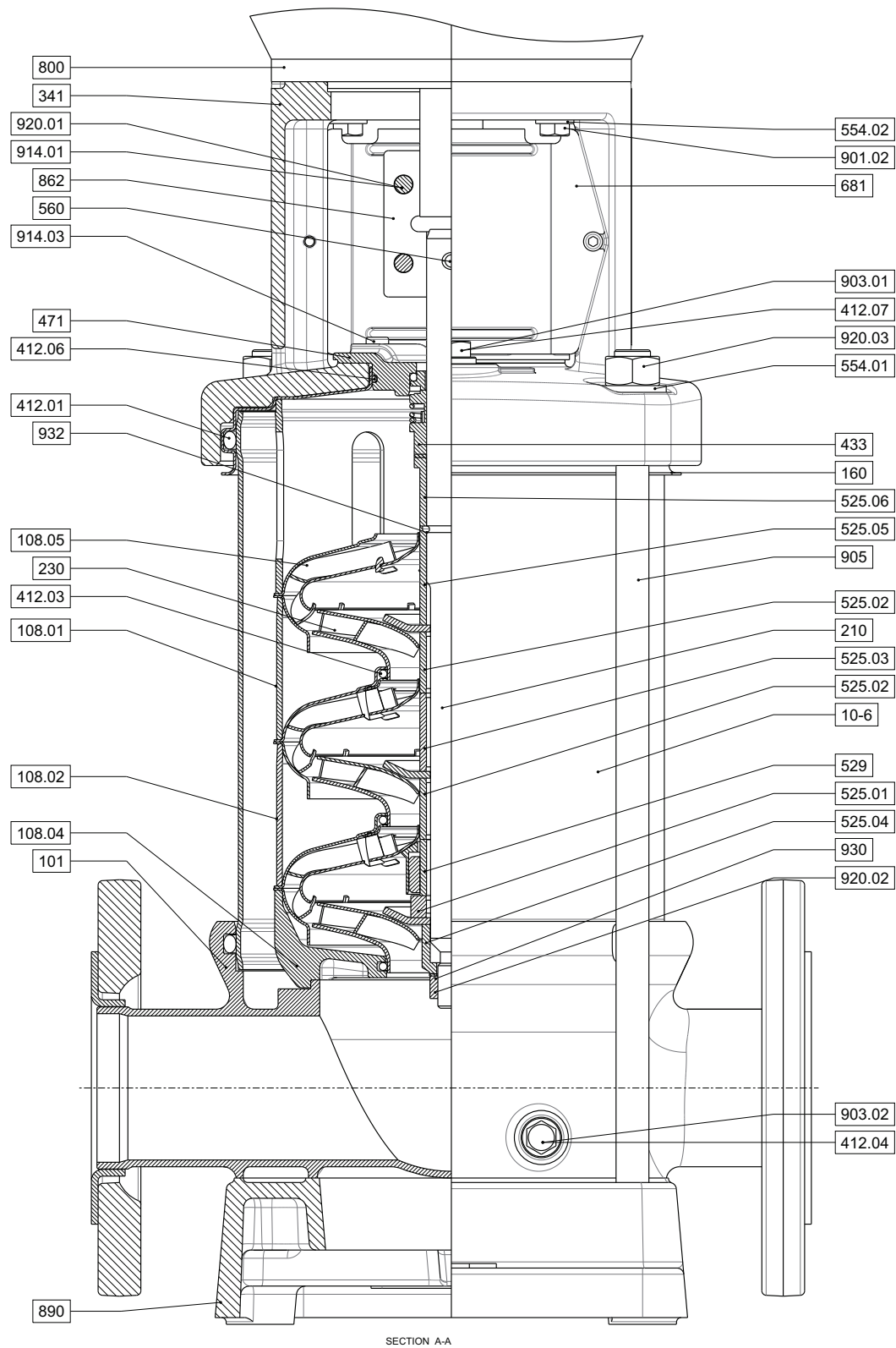

Sectional drawing DPV(S)F 25 B

20110396 F



8.1.9 Sectional drawing DPV(S)F 40, 60 B

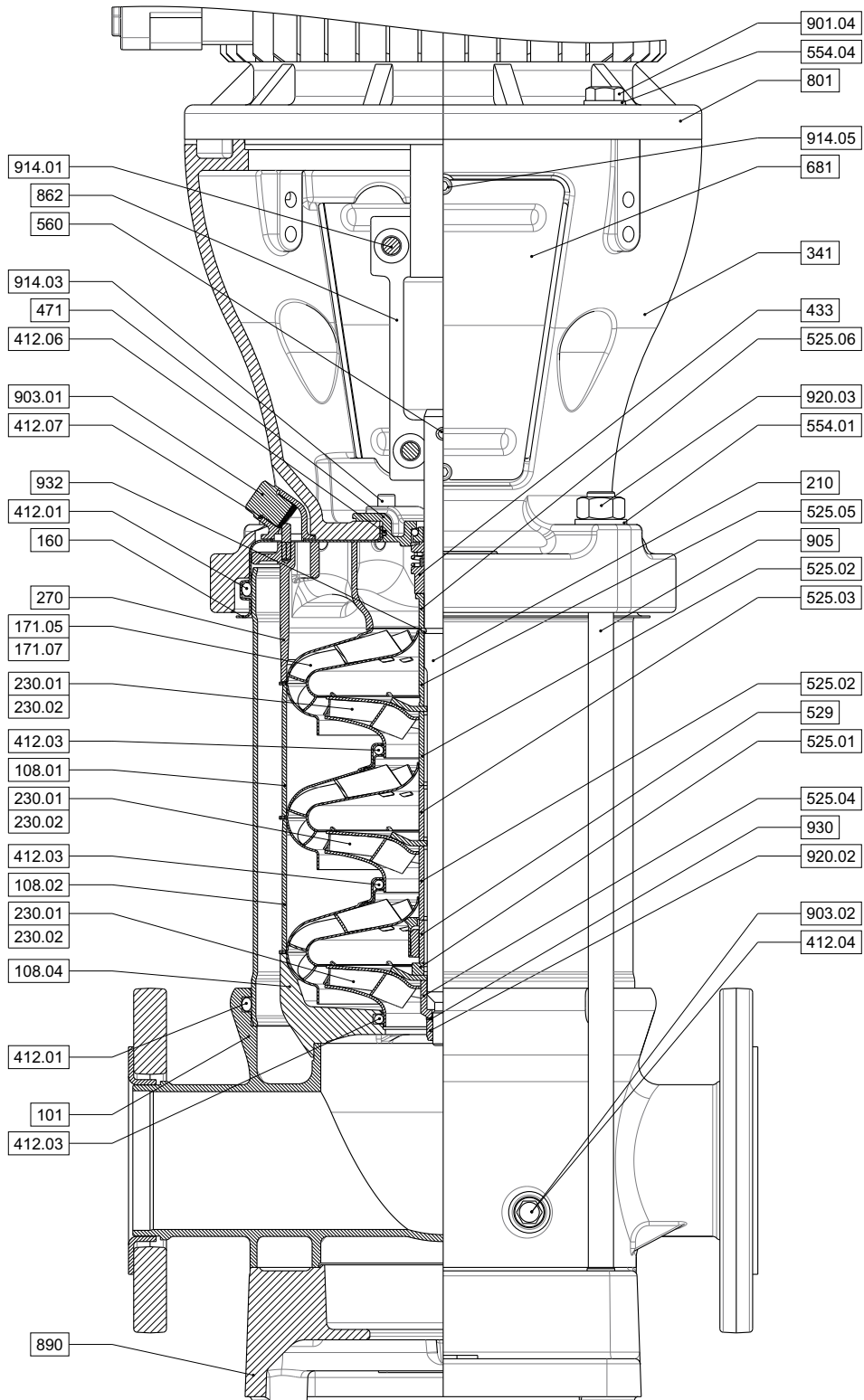

SECTION A-A

Sectional drawing DPV(S)F 40, 60 B

8.1.10 Sectional drawing DPVCF 85 B

0303

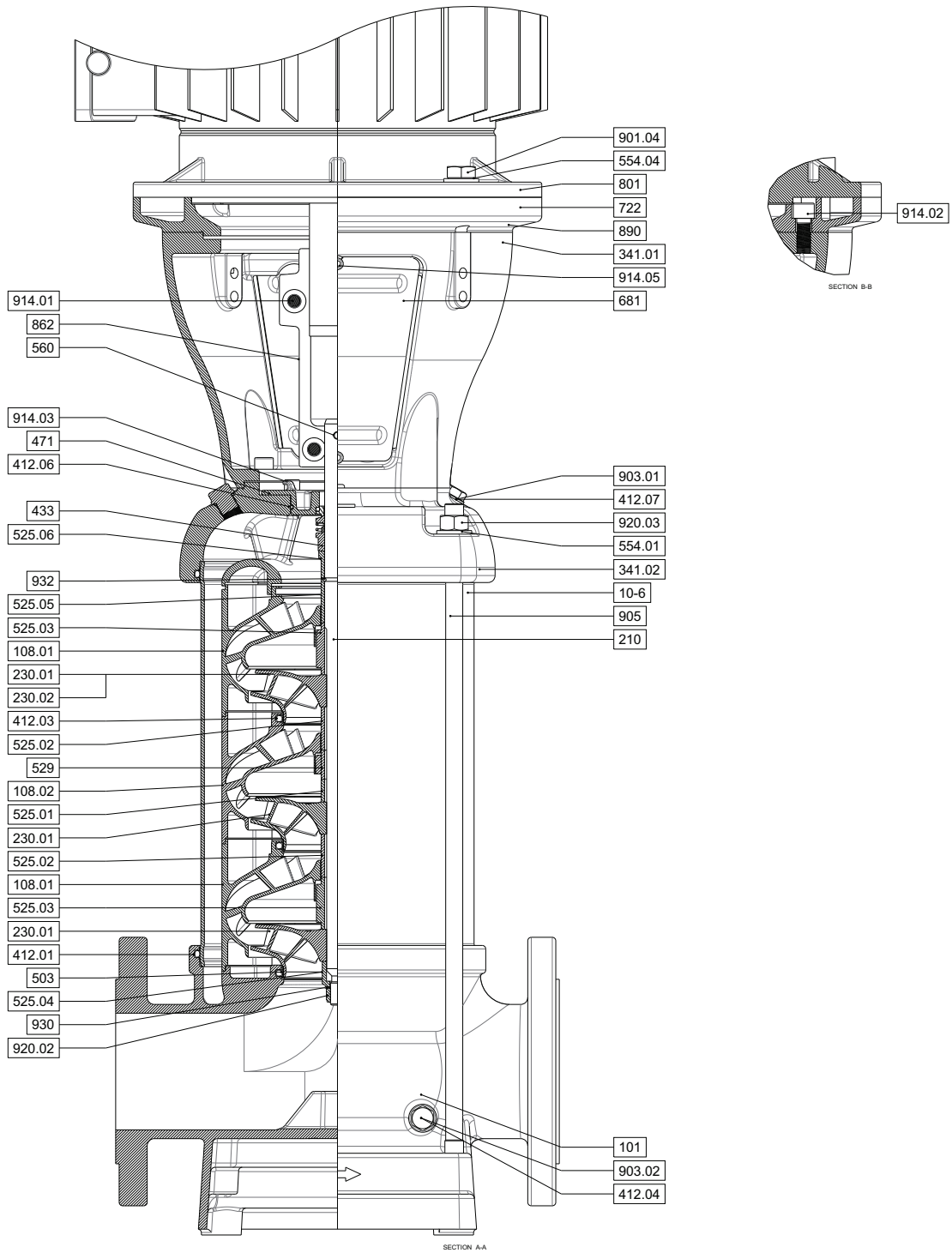

Sectional drawing DPVCF 85 B



8.1.11 Sectional drawing DPV(S)F85 B

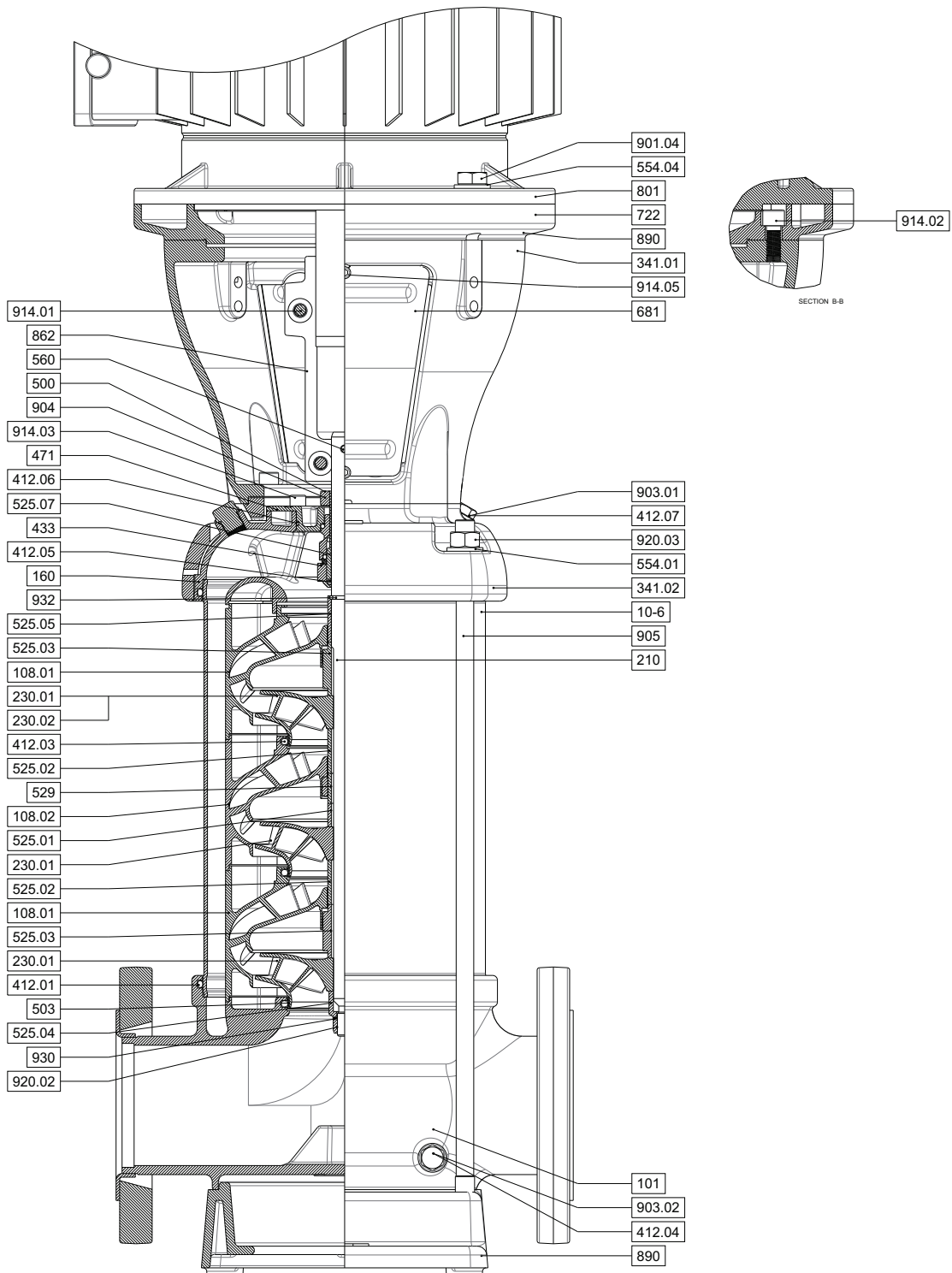

Sectional drawing DPV(S)F 85 B

8.1.12 Sectional drawing DPV(S)F125 B

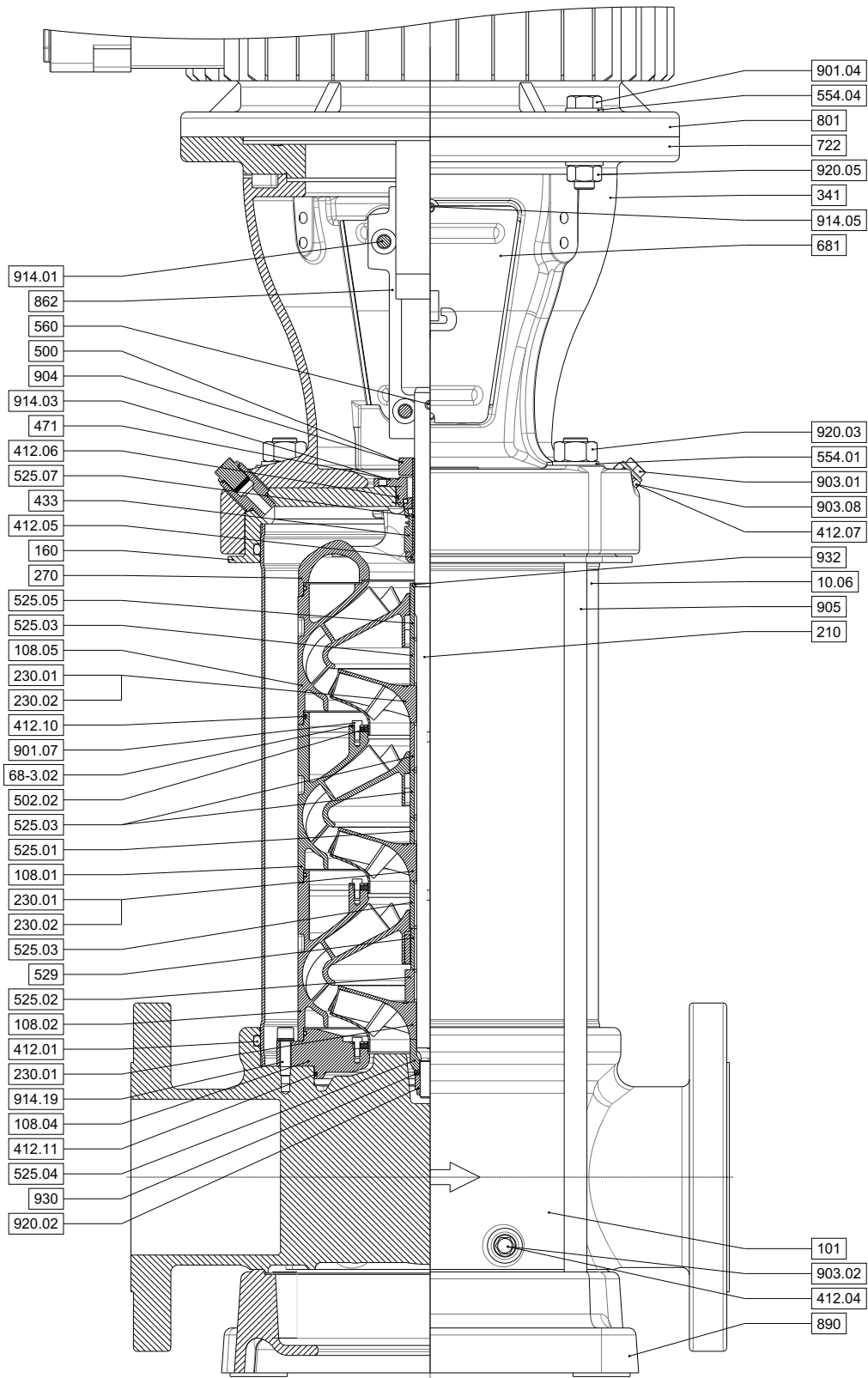

Sectional drawing DPV(S)F 125 B

20151637 C



# 9 Medium handled

## 9.1 Medium handled

Media description	Media group	Chemical formula	Max. conc. [%]	Max. PH .	Max. Temp. {C}	Model	Material shaft seal			Material pump
							rotor	stator	elastomer	elastomer
Acetic acid	Acid	(CH <sub>3</sub> COOH	5		20	V	SiC	Ca	EPDM	EPDM
Acetic anhydride	Weak acid derivative	(CH <sub>3</sub> CO) <sub>2</sub> O	20		20	V	SiC	Ca	EPDM	EPDM
Acetone	Ketone	(CH <sub>3</sub> ) <sub>2</sub> CO				VC	SiC	Ca	EPDM	EPDM
Acetyl chloride		CH <sub>3</sub> COCl			40	VS	SiC	Ca	EPDM	EPDM
Alcaline (bottle rinse)	Rinsing		2	< 9.5	40	V	TuC	TuC	HNBR	HNBR
Alcohol (Ethanol)	Hydrocarbon	C <sub>2</sub> H <sub>5</sub> OH	100		60	V	SiC	Ca	EPDM	EPDM
Alum (potassium aluminium sulphate)	Salt	MI MIII (SO <sub>4</sub> ) <sub>2</sub>	3		80	VS	SiC	Ca	FPM	FPM
Aluminium chloride	Halide	AlCl <sub>3</sub>	5		50	VS	SiC	Ca	EPDM	EPDM
Aluminium chloride	Halide	AlCl <sub>3</sub>	25		20	VS	SiC	Ca	EPDM	EPDM
Aluminium sulphate	Salt	Al <sub>2</sub> (SO <sub>4</sub> ) <sub>3</sub>			20	V	SiC	Ca	EPDM	EPDM
Aluminium sulphate	Salt	Al <sub>2</sub> (SO <sub>4</sub> ) <sub>3</sub>	5		Boiling	VS	SiC	Ca	EPDM	EPDM
Ammonia	Strong base	NH <sub>3</sub>				VC	SiC	Ca	EPDM	EPDM
Ammonium bicarbonate	Salt	(NH <sub>4</sub> )HCO <sub>3</sub>	10		40	V	SiC	Ca	EPDM	EPDM
Ammonium sulphate	Salt	(NH <sub>4</sub> ) <sub>2</sub> SO <sub>4</sub>	20		60	V	SiC	Ca	EPDM	EPDM
Antifreeze (glycol base, salt-free)	Alcohol		45		110	V	SiC	Ca	EPDM	EPDM
Beer (not lathery / under pressure)	Alcohol		100		15	V	SiC	Ca	EPDM	EPDM
Benzene	Hydrocarbon solvent	C <sub>6</sub> H <sub>6</sub>				VS	SiC	Ca	FPM	FPM
Boric acid	Acid	H <sub>3</sub> BO <sub>3</sub>				V	SiC	Ca	EPDM	EPDM
Buttermilk	Dairy product	fats + water	100		60	V	SiC	Ca	EPDM	EPDM
Butyl alcohol (butanol)	Hydrocarbon	CH <sub>3</sub> (CH <sub>2</sub> ) <sub>3</sub> OH					SiC	Ca	EPDM	EPDM
Calcium acetate	Salt	C <sub>4</sub> H <sub>6</sub> O <sub>4</sub> Ca	10		60	VS	SiC	Ca	EPDM	EPDM
Calcium nitrate (non-acidic)	Salt	Ca(NO <sub>3</sub> ) <sub>2</sub>	10		60	VS	TuC	TuC	FPM	FPM
Cider (apple cider)	Alcohol	H <sub>2</sub> O + sucrose + alcohol	100		40	V	SiC	Ca	EPDM	EPDM
Citric acid	Acid	C <sub>3</sub> H <sub>4</sub> (OH)(COOH) <sub>3</sub>	5		20	VS	SiC	Ca	FPM	FPM
Copper sulphate	Salt	CuSO <sub>4</sub> ·5H <sub>2</sub> O	5		80	V	TuC	TuC	HNBR	HNBR
Corn oil	Vegetable oil		100		100	VS	SiC	Ca	FPM	FPM
Diesel oil	Hydrocarbons					V	SiC	Ca	FPM	FPM

Media description	Media group	Chemical formula	Max. conc. [%]	Max. PH .	Max. Temp. {C}	Model	Material shaft seal			Material pump
							rotor	stator	elasto-mer	elasto-mer
Diethylene glycol (salt-free)	Alcohol	C <sub>4</sub> H <sub>10</sub> O <sub>3</sub>	100		100	VC	SiC	Ca	EPDM	EPDM
Ethanol (alcohol)	Hydrocarbon	C <sub>2</sub> H <sub>5</sub> OH	100		60	V	SiC	Ca	EPDM	EPDM
Ethylene glycol (salt-free)	Alcohol	(CH <sub>2</sub> OH) <sub>2</sub>	100		100	V	SiC	Ca	EPDM	EPDM
Ferric-III-chloride	Salt	FeCl <sub>3</sub>	5		80	V	TuC	TuC	FPM	FPM
Fuel oil (light)	Hydrocarbon				80	VS	SiC	Ca	FPM	FPM
Glycerin (glycerol)	Alcohol	C <sub>3</sub> H <sub>8</sub> O <sub>3</sub>	40		80	V	SiC	Ca	EPDM	EPDM
Kerosene	Hydrocarbon		100		80	V	SiC	Ca	FPM	FPM
Linseed oil	Vegetable oil		100		60	V	SiC	Ca	FPM	FPM
Linseed oil + 3% sulphur acid	Vegetable oil		100		60	V	SiC	Ca	FPM	FPM
Magnesium sulphate	Salt	MgSO <sub>4</sub>	10		80	V	SiC	Ca	FPM	FPM
Malic acid	Acid	C <sub>4</sub> H <sub>2</sub> O <sub>3</sub>				V	SiC	Ca	FPM	FPM
Methanol	Alcohol	CH <sub>3</sub> OH				V	SiC	Ca	EPDM	EPDM
Methyl glycol (propylene glycol)	Alcohol	C <sub>3</sub> H <sub>6</sub> (OH) <sub>2</sub>	100		20	VC	SiC	Ca	EPDM	EPDM
Milk	Dairy product	fats + water				V	SiC	Ca	EPDM	EPDM
Olive oil	Vegetable oil					VC	SiC	Ca	FPM	FPM
Oxalic acid	Acid	H <sub>2</sub> C <sub>2</sub> O <sub>4</sub>	5		20	V	SiC	Ca	EPDM	EPDM
Oxalic acid	Acid	H <sub>2</sub> C <sub>2</sub> O <sub>4</sub>	5		Boiling	VS	SiC	Ca	FPM	FPM
Oxalic acid	Acid	H <sub>2</sub> C <sub>2</sub> O <sub>4</sub>	10		60	V	SiC	Ca	EPDM	EPDM
Paraffins	Hydrocarbon					V	SiC	Ca	FPM	FPM
Peanut oil	Vegetable oil		100		90	V	SiC	Ca	FPM	FPM
Petroleum	Hydrocarbon	Hydrocarbon	100		80	V	SiC	Ca	FPM	FPM
Potassium chlorate	Salt	KClO <sub>3</sub>				VS	TuC	TuC	HNBR	HNBR
Potassium chloride	Salt	KCl				V	SiC	Ca	EPDM	EPDM
Potassium hydroxide	Salt	KOH	5		40	VS	SiC	Ca	EPDM	EPDM
Potassium nitrate	Salt	KNO <sub>3</sub>	5		30	VS	TuC	TuC	HNBR	HNBR
Potassium sulphate	Salt	K <sub>2</sub> SO <sub>4</sub>	3		20	VS	SiC	Ca	FPM	FPM
Rape-seed oil	Vegetable oil	mixture			100	VS	SiC	Ca	FPM	FPM
Sodium carbonate	Salt	Na <sub>2</sub> CO <sub>3</sub>	6		60	V	SiC	Ca	EPDM	EPDM
Sodium chloride	See sea water	NaCl								
Sodium hydroxide (soda lye)	Salt	NaOH	5		50	VS	TuC	TuC	HNBR	HNBR
Sodium nitrate (non acidic)	Salt	NaNO <sub>3</sub>	10		60	V	SiC	Ca	EPDM	EPDM
Sodium phosphate	Salt	Na <sub>3</sub> PO <sub>4</sub>				V	SiC	Ca	EPDM	EPDM
Sodium sulphate (non acidic)	Salt	Na <sub>2</sub> SO <sub>4</sub>	5		60	V	SiC	Ca	EPDM	EPDM
Soybean oil	Vegetable oil		100		100	V	SiC	Ca	FPM	FPM
Spirits	Alcohol	H <sub>2</sub> O + sucrose + alcohol	40		60	V	SiC	Ca	EPDM	EPDM
Sulphuric acid	Acid	H <sub>2</sub> SO <sub>4</sub>	5		30	VS	TuC	TuC	FPM	FPM

Media description	Media group	Chemical formula	Max. conc. [%]	Max. PH .	Max. Temp. {C}	Model	Material shaft seal			Material pump
							rotor	stator	elasto-mer	elasto-mer
Tannic acid	Acid	C <sub>76</sub> H <sub>52</sub> O <sub>46</sub>	20		80	V	SiC	Ca	FPM	FPM
Tartaric acid	Acid	C <sub>4</sub> H <sub>6</sub> O <sub>6</sub>	8		40	VS	SiC	Ca	FPM	FPM
Vinegar (wine vinegar)	Acid	CH <sub>3</sub> COOH	10		60	VS	SiC	Ca	EPDM	EPDM
Water, untreated / suspended solids <20 ppm	Water	H <sub>2</sub> O + ...	100		60	VC	TuC	Ca	EPDM	EPDM
Water, boiler feed water (conform. Vd TÜV 1466)	Water	H <sub>2</sub> O + ...	100		120	VC	TuC	Ca	EPDM	EPDM E425
Water, brackish	Sea water	H <sub>2</sub> O + ...	100	7	5	V	TuC	TuC	FPM	FPM
Water, brackish	Sea water	H <sub>2</sub> O + ...	100	7	10	V	TuC	TuC	FPM	FPM
Water, brackish	Sea water	H <sub>2</sub> O + ...	100	7	15	VS	TuC	TuC	FPM	FPM
Water, brackish	Sea water	H <sub>2</sub> O + ...	100	7	20	VS	TuC	TuC	FPM	FPM
Water, brackish	Sea water	H <sub>2</sub> O + ...	100	7	25	VS	TuC	TuC	FPM	FPM
Water, coast water	Sea water	H <sub>2</sub> O + ...	100	7	5	VS	TuC	TuC	FPM	FPM
Water, coast water	Sea water	H <sub>2</sub> O + ...	100	7	10	VS	TuC	TuC	FPM	FPM
Water, coast water	Sea water	H <sub>2</sub> O + ...		7	15	VS	TuC	TuC	FPM	FPM
Water, condensate (conform Vd TÜV 1466)	Water	H <sub>2</sub> O + ...	100		100	VS	TuC	Ca	EPDM	EPDM
Water, cooling water	Water	H <sub>2</sub> O + ...			100	VS	TuC	TuC	HNBR	HNBR
Water, de-carbonised (softened)	Water	H <sub>2</sub> O + ...	100		120	V	TuC	TuC	HNBR	HNBR
Water, de-ionised	Water	H <sub>2</sub> O + ...			120	VS	SiC	Ca	EPDM	EPDM
Water, distilled	Water	H <sub>2</sub> O + ...				V	SiC	Ca	EPDM	EPDM
Water, fire fighting	Water	H <sub>2</sub> O + ...	100		60	VC	TuC	TuC	HNBR	HNBR
Water, harbour	Sea water	H <sub>2</sub> O + ...	100	7	5	VS	TuC	TuC	FPM	FPM
Water, harbour	Sea water	H <sub>2</sub> O + ...	100	7	10	VS	TuC	TuC	FPM	FPM
Water, heating (conform Vd TÜV 1466)	Water	H <sub>2</sub> O + ...	100		120	VC	SiC	Ca	EPDM	EPDM
Water, (conform VDI 2035)	Water	H <sub>2</sub> O + ...	100		100	VC	TuC	Ca	EPDM	EPDM
Water, oil water mixture	Water		5		80	V	SiC	Ca	FPM	FPM
Water, ordinary sea water	Sea water	H <sub>2</sub> O + ...	100	7	5	V	TuC	TuC	FPM	FPM
Water, ordinary sea water	Sea water	H <sub>2</sub> O + ...	100	7	10	VS	TuC	TuC	FPM	FPM
Water, ordinary sea water	Sea water	H <sub>2</sub> O + ...	100	7	15	VS	TuC	TuC	FPM	FPM
Water, ordinary sea water	Sea water	H <sub>2</sub> O + ...	100	7	20	VS	TuC	TuC	FPM	FPM



Media description	Media group	Chemical formula	Max. conc. [%]	Max. PH .	Max. Temp. {C}	Model	Material shaft seal			Material pump
							rotor	stator	elastomer	elastomer
Water (Ozon 0.5 mg/l)	Water	H <sub>2</sub> O + ...			25	V	SiC	Ca	EPDM	EPDM
Water, pure (chemically neutral)	Water	H <sub>2</sub> O + ...	100		60	V	SiC	Ca	EPDM	EPDM
Water, rinsing	Water	H <sub>2</sub> O + ...			70	VS	TuC	TuC	FPM	FPM
Water, swimming-pool (chlorine 0.8 mg/l)	Water	H <sub>2</sub> O + ...			25	VS	SiC	Ca	FPM	FPM
Water, tap (drinking water)	Water	H <sub>2</sub> O + ...	100		60	V	SiC	Ca	EPDM	EPDM WRc/ ACS



