

ŘADA S

CELONEREZOVÁ PONORNÁ ČERPADLA



VÝKON: 0.4 ÷ 15 [kW]

MAX. DOPRAVNÍ VÝŠKA: 57 [m]

MAX. PRŮTOK: 138 [m³/hod]



■ ZNAČENÍ ČERPADEL

Příklad 1: **S** **S** - **2** **1** **A** **F**
 Celonere- Sítio Výtláčné Výkon Varianta Plovák
 zový typ [HP]

Příklad 2: **S** **F** - **05** **A** **U** **F**
 Celonere- Patka Výkon Varianta Typ Plovák
 zový typ stojan [HP] oběžného kola

Příklad 3: **80** **(100)** **S** **F** **P** **2** **5.5**
 Výtláčné Výtláčné Celonere- Patka Typ Počet Výkon
 hrdlo [mm] hrdlo [mm] zový typ stojan oběžného polů [kW]
 Varianta kola

■ VLASTNOSTI

- Kompaktní konstrukce, suchý motor, dvojité mechanická SiC ucpávka, doplňková tepelná ochrana (bi-metal), veškeré díly z kvalitní nerez oceli.
- Řada čerpadel S je vhodná pro čerpání agresivních vod a kalů.

■ POUŽITÍ

- Čerpání agresivních kapalin v průmyslu.
- Záchytné a neutralizační jímky i stanice, chemické ČOV, agresivní vody a kaly z chemických provozů, odsíření elektráren, dehtové vody z koksoven apod.

■ TECHNOLOGIE LITÍ

Lité nerezové díly jsou vyrobeny moderními technologiemi přesného lití. Odličky mají hladký povrch, čímž zlepšují hydraulické vlastnosti čerpadel.

■ VITON

Všechny těsnicí kroužky, vývodka kabelu, gufero a pryžové části mechanické ucpávky jsou z vitonu. Volba tohoto materiálu zvyšuje životnost čerpadla při čerpání žíravín a jiných agresivních médií.

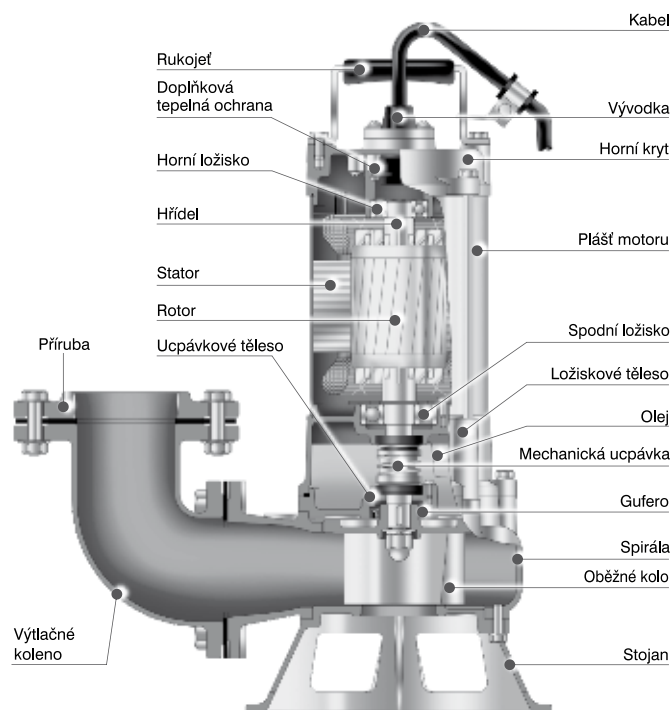

CELONEREZOVÁ PONORNÁ ČERPADLA ODPADNÍCH VOD SS SS-05A • SS-21A

TECHNICKÉ PARAMETRY

Čerpaná kapalina	Teplota kapaliny	0 ÷ 40°C	
	Charakter kapaliny	Agresivní odpadní vody a chemikálie	
	Hodnota pHmax	2 ÷ 14	
Čerpadlo	Konstrukce	Oběžné kolo	Otevřené
		Mechanická ucpávka	Dvojitá mechanická ucpávka
		Ložiska	Uzavřená ložiska mazaná tukem
	Materiál	Horní kryt	ČSN 422942
		Oběžné kolo	ČSN 422942
		Spirála	ČSN 422942
		Sací koš	ČSN 17240
Mech. ucpávka	Motorová strana	CA/CE	
	Čerpadlová strana	SiC/SiC	
Motor	Typ	Suchý motor	
	Izolace • Počet pólů	B (3,7 kW F) • 2P	
	Hz • F/V	50 Hz • 1F/230 V; 3F/400 V	
	Automatické odpojení	Doplňková tepelná ochrana (SS-05A 1F - termostat)	
	Materiál	Plášť motoru	ČSN 17348
		Hlavní hřídel	ČSN 17348
Kabel • Délka		H07 RNF • 10 m	



SS-05A • SS-21A



SS-05AF • SS-21AF



Otevřené oběžné kolo

Typ	Výkon [kW]	Výtlačné hrdlo [mm]	Jmenovité parametry		Maximální parametry		Průchodnost [mm]	Hmotnost		Fáze Napětí	1Ø 230V	3Ø 400V	Plovák*	
			Dopr.výška [m]	Průtok [m³/h]	Dopr.výška [m]	Průtok [m³/h]		1Ø [kg]	3Ø [kg]				230V	400V
SS-05A(F)	0.4	50	7	7.2	10	15.6	10	14	14	Proud [A]	3.3	1.3	ano	ano
SS-21A(F)	0.75	50	10	10.2	14.5	21	10	16	15		5.2	1.9	ano	ano

*Varianta čerpadla s plovákem – v typovém označení – F

PŘÍRUBA

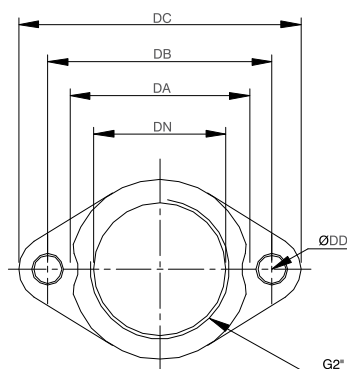

ROZMĚRY

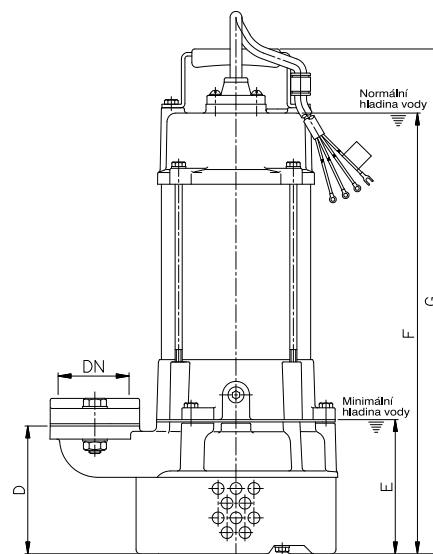
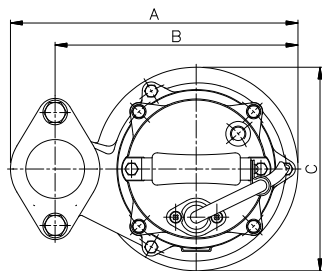

SS-05A • SS-21A

Typ	Rozměry [mm]					
	DN	závit	DA	DB	DC	DD
SS-05A	50	G2"	77	96	121	12
SS-21A	50	G2"	77	96	121	12

Typ	Rozměry [mm]						
	A	B	C	D	E	F	G
SS-05A	245	207	174	109	115	385	439
SS-21A	245	207	174	109	115	385	439

■ KŘIVKY VÝKONU

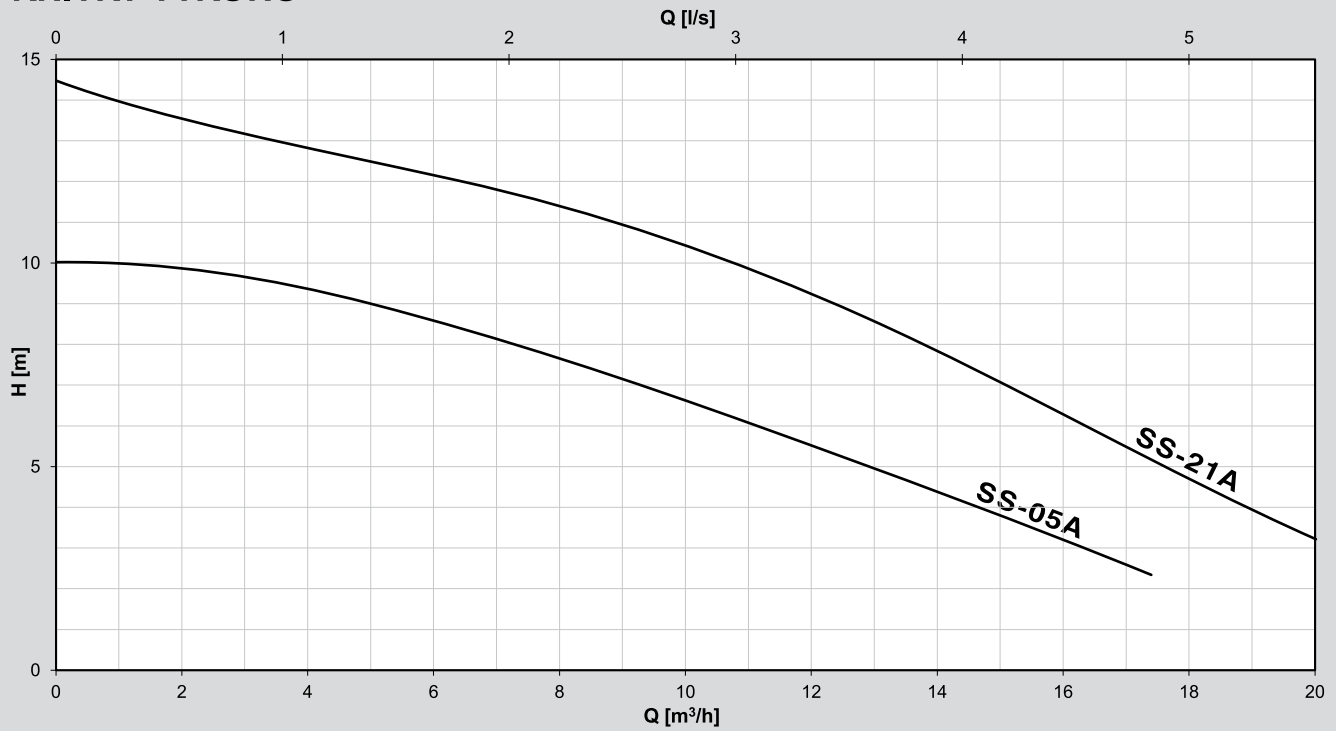

Typ	Q [m³/h]	3	6	9	12	15	18
SS-05A	H [m]	9.7	8.5	7.2	5.5	3.8	
SS-21A	H [m]	13.1	12.2	11	9.2	7	4.8

■ SPOUŠTĚCÍ ZAŘÍZENÍ – ROZMĚRY

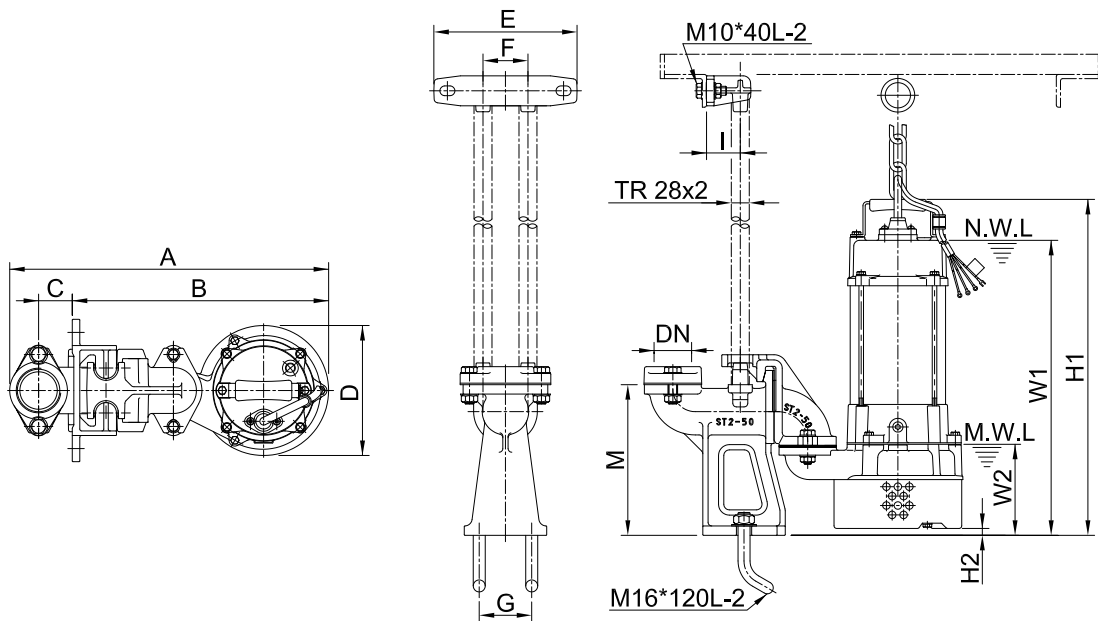

SS-05A • SS-21A : ST2-50

Typ	Rozměry [mm]																	
	DN	závit	A	B	C	D	E	F	G	I	M	N	O	P	W1	W2	H1	H2
SS-05A	50	G2"	426	342	45	174	190	60	70	45	201				394	122	448	9
SS-21A	50	G2"	426	342	45	174	190	60	70	45	201				394	122	448	9

CELONEREZOVÁ PONORNÁ KALOVÁ ČERPADLA SF SF-05AU • SF-21AU • 80SFU21.5 • 80SFU22.2 • 80SFU23.7 • 80SFU25.5 • 80SFU27.5 • 80SFU211

TECHNICKÉ PARAMETRY

Čerpaná kapalina	Teplota kapaliny	0 ÷ 40°C	
	Charakter kapaliny	Agresivní kaly a chemikálie	
	Hodnota pHmax	2 ÷ 14	
Čerpadlo	Konstrukce	Oběžné kolo	Otevřené
		Mechanická ucpávka	Dvojitá mechanická ucpávka
		Ložiska	Uzavřená ložiska mazaná tukem
	Materiál	Horní kryt	ČSN 422942
		Oběžné kolo	ČSN 422942
		Spirála	ČSN 422942
Mech. ucpávka	Motorová strana	CA/CE	
	Čerpadlová strana	SiC/SiC	
Motor	Typ	Suchý motor	
	Izolace • Počet pólů	B (0,4 a 0,75kW) • 2 P F (1,5 až 3,7kW) • 2 P H (5,5 až 11kW) • 2 P	
	Hz • F/V	50 Hz • 1F/230 V; 3F/400 V	
	Spouštění	Přímé (11 kW Y-Δ)	
	Automatické odpojení	Doplňková tepelná ochrana (11 kW ochrana MTP)	
	Materiál	Plášť motoru	ČSN 17346
		Hlavní hřídel	ČSN 17346 (od 11kW DIN 1.4542)
Kabel • Délka		H07 RNF • 10 m (11 kW - 3 kabely: 2 silové (Y-Δ), 1 signalizační (WD + MTP))	



Typ	Výkon [kW]	Výtláčné hrdlo [mm]	Jmenovité parametry		Maximální parametry		Průchodnost [mm]	Hmotnost		Fáze Napětí	Plovák*			
			Dopr. výška [m]	Průtok [m³/h]	Dopr. výška [m]	Průtok [m³/h]		1Ø [kg]	3Ø [kg]		230V	400V	230V	400V
SF-05AU(F)	0,4	50	6	9	9,5	19,2	35	15	14	Proud [A]	3,3	1,3	ano	ano
SF-21AU(F)	0,75	50	8	12	12,5	24	35	16	15		5,2	1,9	ano	ano
80SFU21.5	1,5	80	8,5	24	16	45	50	26,5			3,4			
80SFU22.2	2,2	80	13	24	19	51	50	29			5,0			
80SFU23.7	3,7	80	17,5	30	25	69	50	40			7,8			
80SFU25.5	5,5	80	21	36	29	78	50	61			11,4			
80SFU27.5	7,5	80	26	36	37	84	50	67			15,2			
80SFU211	11	80	33	36	42,5	90	50	76			21,6			

*Varianta čerpadla s plovákem – v typovém označení – F

PŘÍRUBA

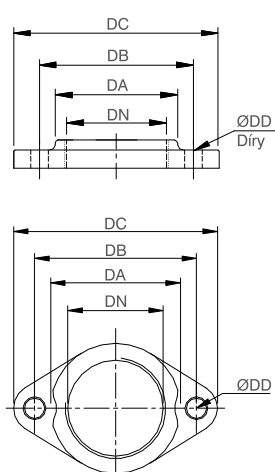

ROZMĚRY

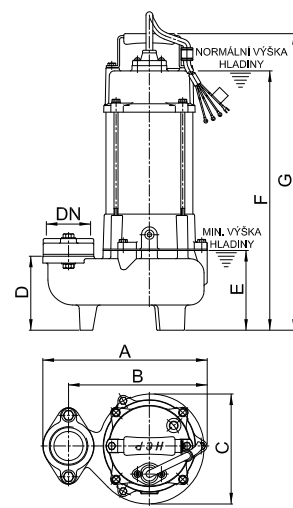

SF-05A • SF-21A

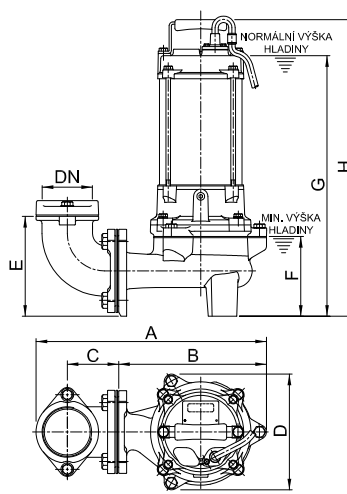

80SFU21.5 • 80SFU22.2

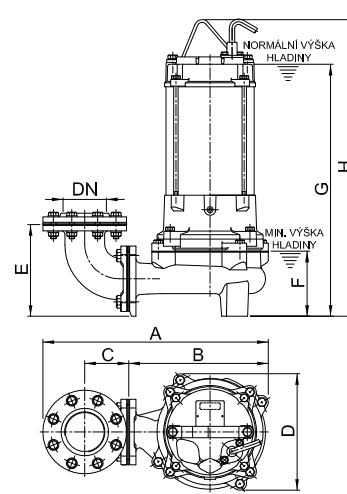

80SFU23.7 • 80SFU25.5
• 80SFU27.5 • 80SFU211

Typ	Rozměry [mm]						Počet děr
	DN	závit	DA	DB	DC	DD	
SF-05AU	50	G2"	77	96	121	12	2
SF-21AU	50	G2"	77	96	121	12	2
80SFU21.5	80	G3"	110	130	155	12	2
80SFU22.2	80	G3"	110	130	155	12	2
80SFU23.7	80	R3"	110	150	185	15	8
80SFU25.5	80	R3"	110	150	185	15	8
80SFU27.5	80	R3"	110	150	185	15	8
80SFU211	80	R3"	110	150	185	15	8

Typ	Rozměry [mm]							
	A	B	C	D	E	F	G	H
SF-05AU	237	199	154	99	109	372	427	
SF-21AU	237	199	154	99	109	372	427	
80SFU21.5	402	260	87	202	174	139	454	517
80SFU22.2	402	260	87	202	174	139	454	517
80SFU23.7	476	286	98	223	203	143	498	561
80SFU25.5	499	309	98	258	203	144	558	657
80SFU27.5	499	309	98	258	203	144	558	657
80SFU211	499	309	98	258	203	144	598	697

■ KŘIVKY VÝKONU

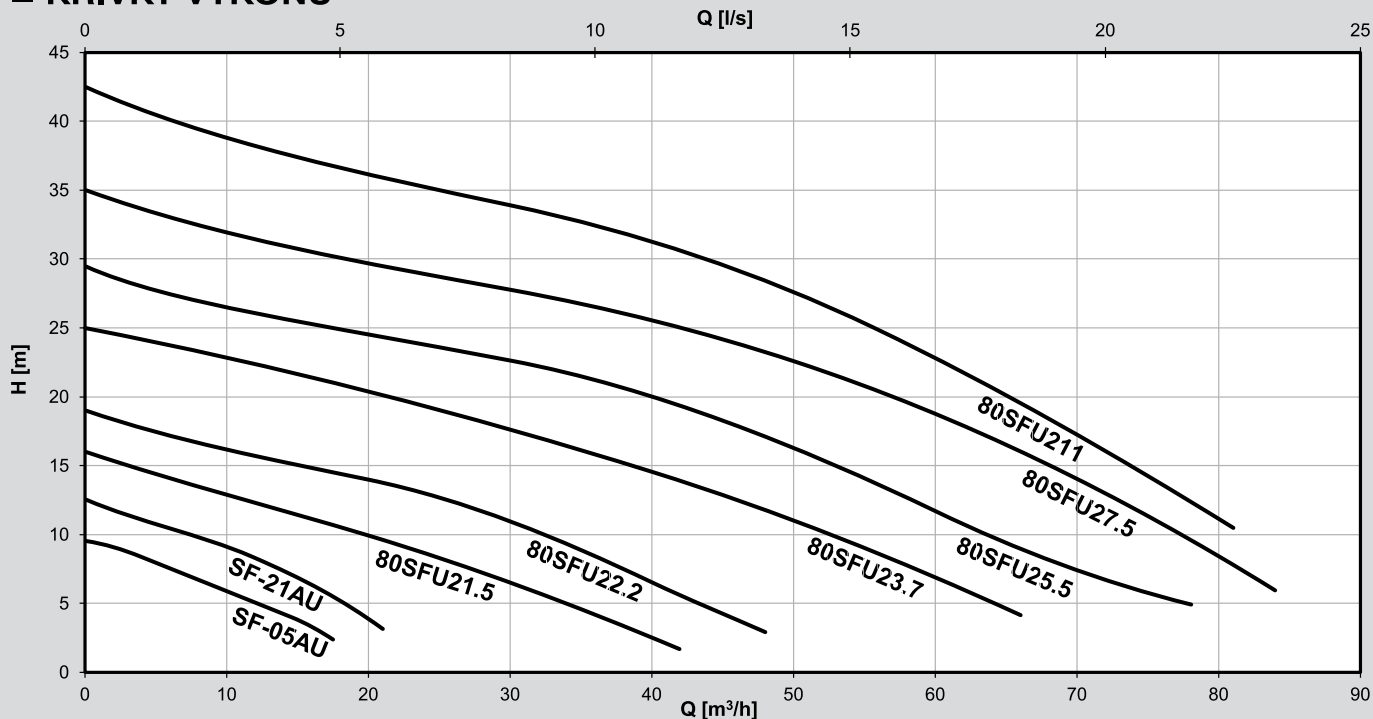

Typ	Q [m³/h]	6	12	18	24	30	36	42	48	54	60	66	72	78	84
SF-05AU		7.5	5.1												
SF-21AU		10.5	8.4	5.1											
80SFU21.5		14.0	12.3	10.6	8.6	6.4	4.2	1.7							
80SFU22.2		17.2	15.7	14.3	13.0	11.0	8.5	5.3	3						
80SFU23.7		24.0	22.4	20.9	19.3	17.6	15.8	14.0	11.7	9.4	7	4.1			
80SFU25.5		27.6	26.1	24.8	23.6	22.8	21.2	19.5	17.0	14.7	11.8	9.0	6.6	5.0	
80SFU27.5		33	31.6	30.1	28.8	27.5	26.5	25.3	23.4	21.5	18.7	15.9	13.0	9.4	6.0
80SFU211		40.0	38.2	37.0	35.2	33.7	32.4	30.7	28.4	25.7	22.8	19.7	16.0	12.0	6.0

■ SPOUŠTĚCÍ ZAŘÍZENÍ – ROZMĚRY

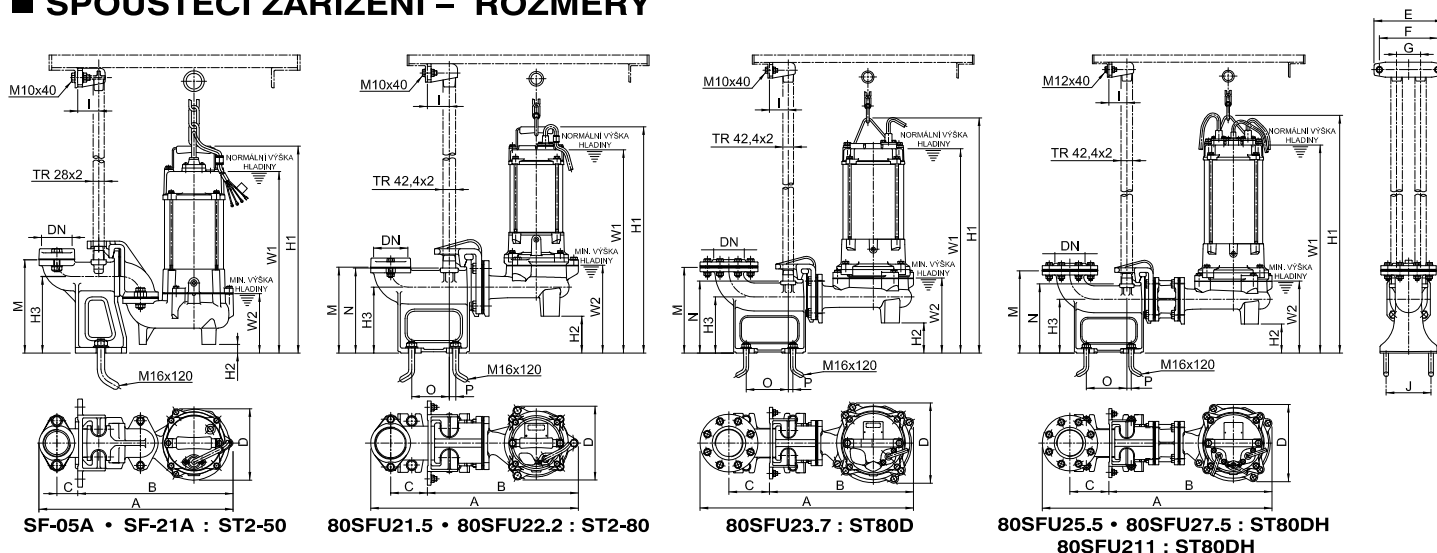

Typ	Rozměry [mm]																			
	DN	závit	A	B	C	D	E	F	G	I	J	M	N	O	P	W1	W2	H1	H2	H3
SF-05AU	50	G2"	418	335	45	154	190	155	60	45	70	201				391	128	446	19	165
SF-21AU	50	G2"	418	335	45	154	190	155	60	45	70	201				391	128	446	19	165
80SFU21.5	80	G3"	567	412	100	202	230	195	80	60	120	235	232	102	18	555	240	618	101	180
80SFU22.2	80	G3"	567	412	100	202	230	195	80	60	120	235	232	102	18	555	240	618	101	180
80SFU23.7	80	R3"	661	439	130	223	230	195	80	60	150	275	231	135	15	595	240	658	98	180
80SFU25.5	80	R3"	768	545	130	258	230	195	80	60	150	275	231	135	15	655	241	754	97	180
80SFU27.5	80	R3"	768	545	130	258	230	195	80	60	150	275	231	135	15	655	241	754	97	180
80SFU211	80	R3"	768	545	130	258	230	195	80	60	150	275	231	135	15	695	241	794	97	180

CELONEREZOVÁ PONORNÁ KALOVÁ ČERPADLA SF 80SFP21.5 • 80SFP22.2 • 80SFP23.7 • 80(100)SFP25.5 • 80(100)SFP27.5 • 80(100)SFP211 • 80(100)SFP215

■ TECHNICKÉ PARAMETRY

Čerpaná kapalina	Teplota kapaliny	0 ÷ 40°C	
	Charakter kapaliny	Agresivní kaly a chemikálie	
	Hodnota pHmax	2 ÷ 14	
Čerpadlo	Konstrukce	Oběžné kolo	Otevřené
		Mechanická ucpávka	Dvojitá mechanická ucpávka
		Horní kryt	ČSN 422942
	Materiál	Ložiska	Uzavřená ložiska mazaná tukem
		Oběžné kolo	ČSN 422942
		Spirála	ČSN 422942
		Sací víko	ČSN 422942
Mech. ucpávka	Motorová strana	CA/CE	
	Čerpadlová strana	SiC/SiC	
Motor	Typ	Suchý motor	
	Izolace • Počet pólů	F 1,5 až 3,7 kW • H 5,5 až 15 kW • 2P	
	Hz • F • V	50 Hz • 3F • 400 V	
	Spouštění	Přímé (11 a 15 kW Y-Δ)	
	Automatické odpojení	Doplňková tepelná ochrana (11 a 15 kW ochrana MTP)	
	Materiál	Plášť motoru	ČSN 17346
		Hlavní hřídel	ČSN 17346 (od 11 kW DIN 1.4542)
Kabel • Délka		H07 RNF • 10 m (11 a 15 kW - 3 kabely; 2 silové (Y-Δ), 1 signalizační (WD + MTP))	



80SFP21.5 • 80SFP22.2



80SFP23.7 • 80(100)SFP25.5 • 80(100)SFP27.5
• 80(100)SFP211 • 80(100)SFP215



Typ P
Dvoulopatkové otevřené oběžné kolo

Typ	Výkon [kW]	Výtlačné hrdlo [mm]	Jmenovité parametry		Maximální parametry		Průchodnost [mm]	Hmotnost		Fáze Napětí	1Ø 230V	3Ø 400V
			Dopr. výška [m]	Průtok [m³/h]	Dopr. výška [m]	Průtok [m³/h]		1Ø	3Ø			
80SFP21.5	1.5	80	8.5	36	16.5	63	35	28.5	Proud [A]			3.4
80SFP22.2	2.2	80	13.0	36	20.5	69	35	31.5				5.0
80SFP23.7	3.7	80	20.5	36	28.5	84	32	43				7.8
80(100)SFP25.5	5.5	80	28.0	36	35.0	96	30	67				11.4
		100	21.5	60	35.0	114						15.2
80(100)SFP27.5	7.5	80	35.5	36	43.0	108	30	73				21.6
		100	29.0	60	43.0	123						28.0
80(100)SFP211	11.0	80	46.0	36	54.0	123	30	82				
		100	39.5	60	54.0	138						
80(100)SFP215	15.0	80	50.0	48	57.0	138	30	92				
		100	44.0	72	57.0	138						

■ PŘÍRUBA

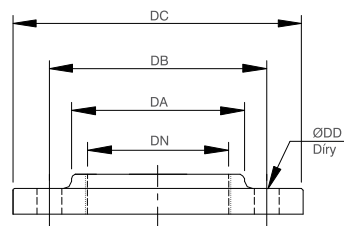

■ ROZMĚRY

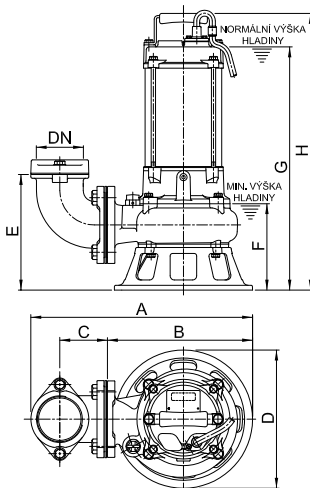

80SFP21.5 • 80SFP22.2

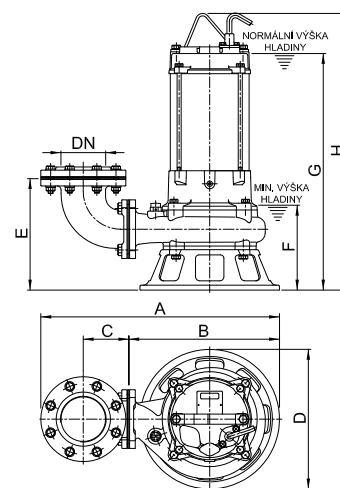

80SFP23.7 • 80(100)SFP25.5 • 80(100)SFP27.5
80(100)SFP211 • 80(100)SFP215

Typ	Rozměry [mm]						Počet děr
	DN	závit	DA	DB	DC	DD	
80SFP21.5	80	G3"	110	130	155	12	2
80SFP22.2	80	G3"	110	130	155	12	2
80SFP23.7	80	R3"	110	150	185	15	8
80(100)SFP25.5	80	R3"	110	150	185	15	8
	100	R4"	136	175	210	15	8
80(100)SFP27.5	80	R3"	110	150	185	15	8
	100	R4"	136	175	210	15	8
80(100)SFP211	80	R3"	110	150	185	15	8
	100	R4"	136	175	210	15	8
80(100)SFP215	80	R3"	110	150	185	15	8
	100	R4"	136	175	210	15	8

Typ	Rozměry [mm]							
	A	B	C	D	E	F	G	H
80SFP21.5	417	275	88	260	218	163	458	421
80SFP22.2	417	275	88	260	218	163	458	421
80SFP23.7	495	305	98	290	250	176	505	568
80(100)SFP25.5	563	373	98	345	271	198	585	684
	590	373	113	345	276	198	585	684
80(100)SFP27.5	563	373	98	345	271	198	585	684
	590	373	113	345	276	198	585	684
80(100)SFP211	563	373	98	345	271	198	625	724
	591	373	113	345	276	198	625	724
80(100)SFP215	563	373	98	345	271	198	665	764
	591	373	113	345	276	198	665	764

■ KŘIVKY VÝKONU

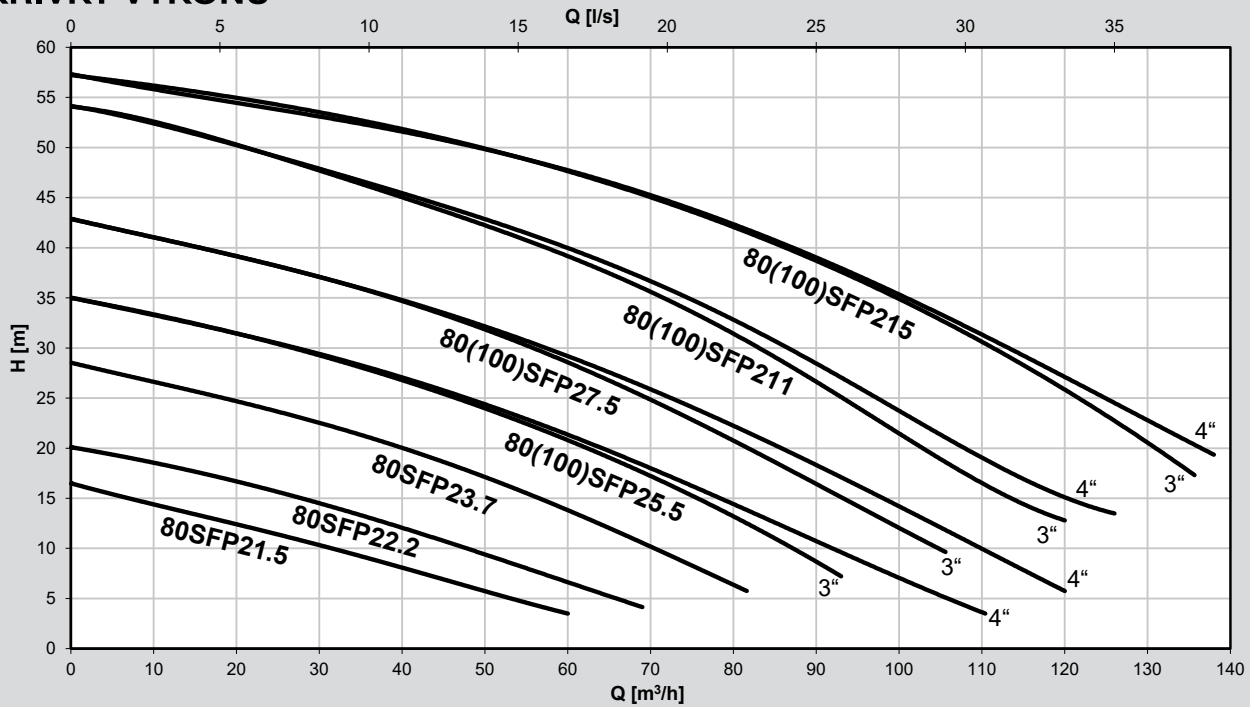

Typ	Q [m³/hDN]	12	24	36	48	60	72	84	96	108	120	138	
80SFP21.5	H [m]	80	14.0	11.6	9.0	6.2	3.5						
80SFP22.2		80	18.2	15.8	13.0	10.2	6.4	3.5					
80SFP23.7		80	27.4	23.8	21.0	17.8	13.9	9.3	5.0				
80(100)SFP25.5		80	33.0	30.6	27.8	24.6	20.8	16.4	11.3				
		100	33.0	30.6	28.0	25.0	21.4	17.2	13.0	8.5	4.2		
80(100)SFP27.5		80	40.4	38.4	36.0	32.4	28.4	23.9	19.2	13.8			
		100	40.4	38.3	36.0	32.8	29.1	25.0	21.0	15.6	10.6	5.6	
80(100)SFP211		80	52.5	48.9	46.2	42.8	39.2	35.0	30.0	23.2	17.4	12.7	
		100	52.5	48.9	46.3	43.4	40.2	36.2	31.0	25.6	20.0	15.6	
80(100)SFP215		80	56.0	54.0	53.0	50.0	48.0	45.0	41.0	37.0	31.5	25.7	16.0
		100	56.0	54.0	53.0	50.0	48.0	45.0	41.0	37.5	32.0	27.0	19.8

■ SPOUŠTĚCÍ ZAŘÍZENÍ – ROZMĚRY

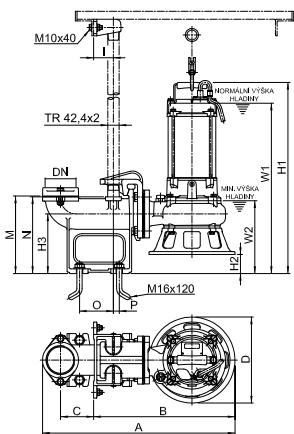

80SFP21.5 • 80SFP22.2 : ST2-80

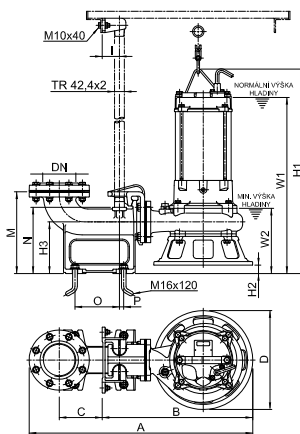

80SFP23.7 • 3" : ST80D

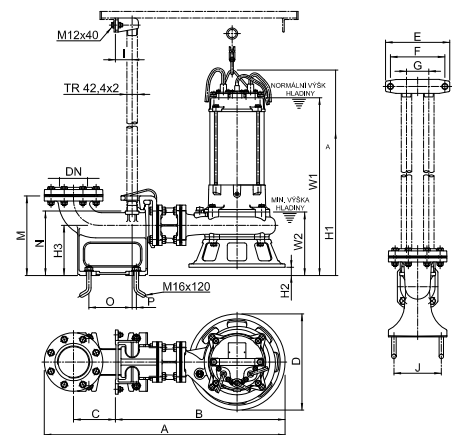

80SFP25.5 • 80SFP27.5 • 80SFP211 • 80SFP215 • 3" : ST80DH
100SFP25.5 • 100SFP27.5 • 100SFP211 • 100SFP215 • 4" : ST100/80BH

Typ	Rozměry [mm]																			
	DN	závit	A	B	C	D	E	F	G	I	J	M	N	O	P	W1	W2	H1	H2	H3
80SFP21.5	80	G3"	582	428	100	260	230	195	80	60	120	235	232	102	18	515	220	578	58	180
80SFP22.2	80	G3"	582	428	100	260	230	195	80	60	120	235	232	102	18	515	220	578	58	180
80SFP23.7	80	R3"	680	458	130	290	230	195	80	60	150	275	231	135	15	555	226	618	50	180
80(100)SFP25.5	80	R3"	832	609	130	345	230	195	80	60	150	275	231	135	15	615	228	714	30	180
	100	R4"	864	609	150	345	230	195	80	60	170	285	231	155	15	615	228	714	30	180
80(100)SFP27.5	80	R3"	832	609	130	345	230	195	80	60	150	275	231	135	15	615	228	714	30	180
	100	R4"	864	609	150	345	230	195	80	60	170	285	231	155	15	615	228	714	30	180
80(100)SFP211	80	R3"	832	609	130	345	230	195	80	60	150	275	231	135	15	655	228	754	30	180
	100	R4"	864	609	150	345	230	195	80	60	170	285	231	155	15	655	228	754	30	180
80(100)SFP215	80	R3"	828	605	130	345	230	195	80	60	150	275	231	135	15	695	228	794	30	180
	100	R4"	860	605	150	345	230	195	80	60	170	285	231	155	15	695	228	794	30	180



www.k-h.cz

Distributor: